

1/10 LUXURY ELECTRIC TOURING CAR FWD

# **XRAY X4F**



**INSTRUCTION MANUAL**  
**FOR X4F'25 EDITION**

## BEFORE YOU START

This is a high-competition, high-quality RC car intended for persons aged 16 years and older with previous experience building and operating RC model racing cars. This is not a toy; it is a precision racing model. This model racing car is not intended for use by beginners, inexperienced customers, or by children without direct supervision of a responsible, knowledgeable adult. If you DO NOT fulfill these requirements, please return the kit in unused and unassembled form back to the shop where you have purchased it.

Before building and operating your XRAY, **YOU MUST** read through all of the operating instructions and instruction manual and fully understand them to get the maximum enjoyment and prevent unnecessary damage.

## CUSTOMER SUPPORT

We have made every effort to make these instructions as easy to understand as possible. However, if you have any difficulties, problems, or questions, please DO NOT hesitate to contact the XRAY support team at [info@teamxray.com](mailto:info@teamxray.com). Also, please visit our Web site at [www.teamxray.com](http://www.teamxray.com) to find the latest updates, set-up information, option parts, and many other goodies. We pride ourselves on taking excellent care of our customers.

You can join thousands of XRAY fans and enthusiasts in our online community at: [www.teamxray.com](http://www.teamxray.com)

Read carefully and fully understand the instructions before beginning assembly.

Make sure you review this entire manual, download and use set-up book from the web, and examine all details carefully. If for some reason you decide this is not what you wanted or expected, **DO NOT continue any further**. Your hobby dealer can not accept your kit for return or exchange after it has been partially or fully assembled.

Contents of the box may differ from pictures. In line with our policy of continuous product development, the exact specifications of the kit may vary without prior notice.

### XRAY Europe

K Vystavisku 6992  
91101 Trenčín  
Slovakia, EUROPE  
Phone: 421-32-7401100  
Fax: 421-32-7401109  
E-mail: [info@teamxray.com](mailto:info@teamxray.com)

### XRAY USA

RC America, 2030 Century Center Blvd #15  
Irving, TX 75062  
USA  
Phone: (214) 744-2400  
Fax: (214) 744-2401  
E-mail: [xray@rcamerica.com](mailto:xray@rcamerica.com)

**FAILURE TO FOLLOW THESE INSTRUCTIONS WILL BE CONSIDERED AS ABUSE AND/OR NEGLIGENCE.**

## SAFETY PRECAUTIONS

Contains:

LEAD (CAS 7439-92-1) ANTIMONY (CAS 7440-36-0)

WARNING: This product contains a chemical known to the state of California to cause cancer and birth defects or other reproductive harm.

CAUTION: CANCER HAZARD

Contains lead, a listed carcinogen. Lead is harmful if ingested. Wash thoroughly after using. DO NOT use product while eating, drinking or using tobacco products. May cause chronic effects to gastrointestinal tract, CNS, kidneys, and blood. **MAY CAUSE BIRTH DEFECTS.**

When building, using and/or operating this model always wear protective glasses and gloves.

Take appropriate safety precautions prior to operating this model. You are responsible for this model's assembly and safe operation! Please read the instruction manual before building and operating this model and follow all safety precautions. Always keep the instruction manual at hand for quick

reference, even after completing the assembly. Use only genuine and original authentic XRAY parts for maximum performance. Using any third party parts on this model will void warranty immediately.

Improper operation may cause personal and/or property damage. XRAY and its distributors have no control over damage resulting from shipping, improper construction, or improper usage. XRAY assumes and accepts no responsibility for personal and/or property damages resulting from the use of improper building materials, equipment and operations. By purchasing any item produced by XRAY, the buyer expressly warrants that he/she is in compliance with all applicable federal, state and local laws and regulation regarding the purchase, ownership and use of the item. The buyer expressly agrees to indemnify and hold harmless XRAY for all claims resulting directly or indirectly from the purchase, ownership or use of the product. By the act of assembling or operating this product, the user accepts all resulting liability. If the buyer is not prepared to accept this liability, then he/she should return this kit in new, unassembled, and unused condition to the place of purchase.



## IMPORTANT NOTES - GENERAL

- This product is not suitable for children under 16 years of age without the direct supervision of a responsible and knowledgeable adult.
- Carefully read all manufacturers warnings and cautions for any parts used in the construction and use of your model.
- Assemble this kit only in places away from the reach of very small children.
- First-time builders and users should seek advice from people who have building experience in order to assemble the model correctly and to allow the model to reach its performance potential.
- Exercise care when using tools and sharp instruments.
- Take care when building, as some parts may have sharp edges.
- Keep small parts out of reach of small children. Children must not be allowed to put any parts in their mouth, or pull vinyl bag over their head.
- Read and follow instructions supplied with paints and/or cement, if used (not included in kit).
- Immediately after using your model, DO NOT touch equipment on the model such as the motor and speed controller, because they generate high temperatures. You may seriously burn yourself seriously touching them.
- Follow the operating instructions for the radio equipment at all times.
- DO NOT put fingers or any objects inside rotating and moving parts, as this may cause damage or serious injury as your finger, hair, clothes, etc. may get caught.
- Be sure that your operating frequency is clear before turning on or running your model, and never share the same frequency with somebody else at the same time. Ensure that others are aware of the operating frequency you are using and when you are using it.
- Use a transmitter designed for ground use with RC cars. Make sure that no one else is using the same frequency as yours in your operating area. Using the same frequency at the same time, whether it is driving, flying or sailing, can cause loss of control of the RC model, resulting in a serious accident.
- Always turn on your transmitter before you turn on the receiver in the car. Always turn off the receiver before turning your transmitter off.
- Keep the wheels of the model off the ground when checking the operation of the radio equipment.
- Disconnect the battery pack before storing your model.
- When learning to operate your model, go to an area that has no obstacles that can damage your model if your model suffers a collision.
- Remove any sand, mud, dirt, grass or water before putting your model away.
- If the model behaves strangely, immediately stop the model, check and clear the problem.
- To prevent any serious personal injury and/or damage to property, be responsible when operating all remote controlled models.
- The model car is not intended for use on public places and roads or areas where its operation can conflict with or disrupt pedestrian or vehicular traffic.
- Because the model car is controlled by radio, it is subject to radio interference from many sources that are beyond your control. Since radio interference can cause momentary loss of control, always allow a safety margin in all directions around the model in order to prevent collisions.
- DO NOT use your model:
  - Near real cars, animals, or people that are unaware that an RC car is being driven.
  - In places where children and people gather
  - In residential districts and parks
  - In limited indoor spaces
  - In wet conditions
  - In the street
  - In areas where loud noises can disturb others, such as hospitals and residential areas.
  - At night or anytime your line of sight to the model may be obstructed or impaired in any way.

To prevent any serious personal injury and/or damage to property, please be responsible when operating all remote controlled models.

**XRAY**

## **IMPORTANT NOTES - ELECTRICAL**

- Insulate any exposed electrical wiring (using heat shrink tubing or electrical tape) to prevent dangerous short circuits. Take maximum care in wiring, connecting and insulating cables. Make sure cables are always connected securely. Check connectors for if they become loose. And if so, reconnect them securely. Never use RC models with damaged wires. A damaged wire is extremely dangerous, and can cause short-circuits resulting in fire. Please have wires repaired at your local hobby shop.
- Low battery power will result in loss of control. Loss of control can occur due to a weak battery in either the transmitter or the receiver. Weak running battery may also result in an out of control car if your car's receiver power is supplied by the running battery. Stop operation immediately if the car starts to slow down.
- When not using RC model, always disconnect and remove battery.
- DO NOT disassemble battery or cut battery cables. If the running battery short-circuits, approximately 300W of electricity can be discharged, leading to fire or burns. Never disassemble battery or cut battery cables.
- Use a recommended charger for the receiver and transmitter batteries and follow the instructions correctly. Over-charging, incorrect charging, or using inferior chargers can cause the batteries to become dangerously hot. Recharge battery when necessary. Continual recharging may damage battery and, in the worst case, could build up heat leading to fire. If battery becomes extremely hot during recharging, please ask your local hobby shop for check and/or repair and/or replacement.
- Regularly check the charger for potential hazards such as damage to the cable, plug, casing or other defects. Ensure that any damage is rectified before using the charger again. Modifying the charger may cause short-circuit or overcharging leading to a serious accident. Therefore DO NOT modify the charger.
- Always unplug charger when recharging is finished.
- DO NOT recharge battery while battery is still warm. After use, battery retains heat. Wait until it cools down before charging.
- DO NOT allow any metal part to short circuit the receiver batteries or other electrical/electronic device on the model.
- Immediately stop running if your RC model gets wet as may cause short circuit.
- Please dispose of batteries responsibly. Never put batteries into fire.

## **R/C & BUILDING TIPS**

- Make sure all fasteners are properly tightened. Check them periodically.
- Make sure that chassis screws DO NOT protrude from the chassis.
- For the best performance, it is very important that great care is taken to ensure the free movement of all parts.
- Clean all ball-bearings so they move very easily and freely.
- Tap or pre-thread the plastic parts when threading screws.
- Self-tapping screws cut threads into the parts when being tightened. DO NOT use excessive force when tightening the self-tapping screws because you may strip out the thread in the plastic. We recommended you stop tightening a screw when you feel some resistance.
- Ask your local hobby shop for any advice.

Please support your local hobby shop. We at XRAY Model Racing Cars support all local hobby dealers. Therefore we ask you, if at all possible, to purchase XRAY products at your hobby dealer and give them your support like we do. If you have difficulty finding XRAY products, please check out [www.teamxray.com](http://www.teamxray.com) to get advice, or contact us via email at [info@teamxray.com](mailto:info@teamxray.com), or contact the XRAY distributor in your country.

## **WARRANTY**

XRAY guarantees this model kit to be free from defects in both material and workmanship within 30 days of purchase. The total monetary value under warranty will in no case exceed the cost of the original kit purchased. This warranty does not cover any components damaged by use or modification or as a result of wear. Part or parts missing from this kit must be reported within 30 days of purchase. No part or parts will be sent under warranty without proof of purchase. Should you find a defective or missing part, contact the local distributor. Service and customer support will be provided through local hobby store where you have purchased the kit, therefore make sure to purchase any XRAY products at your local hobby store. This model racing car is considered to be a high-performance racing vehicle. As such this vehicle will be used in an extreme range of conditions and situations, all which may cause premature wear or failure of any component. XRAY has no control over usage of vehicles once they leave the dealer, therefore XRAY can only offer warranty against all manufacturer's defects in materials, workmanship, and assembly at point of sale and before use. No warranties are expressed or implied that cover damage caused by what is considered normal use, or cover or imply how long any model cars' components or electronic components will last before requiring replacement.

Due to the high performance level of this model car you will need to periodically maintain and replace consumable components. Any and all warranty coverage will not cover replacement of any part or component damaged by neglect, abuse, or improper or unreasonable use. This includes

but is not limited to damage from crashing, chemical and/or water damage, excessive moisture, improper or no maintenance, or user modifications which compromise the integrity of components. Warranty will not cover components that are considered consumable on RC vehicles. XRAY does not pay nor refund shipping on any component sent to XRAY or its distributors for warranty. XRAY reserves the right to make the final determination of the warranty status of any component or part.

### **Limitations of Liability**

XRAY makes no other warranties expressed or implied. XRAY shall not be liable for any loss, injury or damages, whether direct, indirect, special, incidental, or consequential, arising from the use, misuse, or abuse of this product and/or any product or accessory required to operate this product. In no case shall XRAY's liability exceed the monetary value of this product.

**Take adequate safety precautions prior to operating this model. You are responsible for this model's assembly and safe operation.**

**Disregard of the any of the above cautions may lead to accidents, personal injury, or property damage. XRAY MODEL RACING CARS assumes no responsibility for any injury, damage, or misuse of this product during assembly or operation, nor any addictions that may arise from the use of this product.**

**All rights reserved.**

## **QUALITY CERTIFICATE**

XRAY MODEL RACING CARS uses only the highest quality materials, the best compounds for molded parts and the most sophisticated manufacturing processes of TQM (Total Quality Management). We guarantee that all parts of a newly-purchased kit are manufactured with the highest regard to quality. However, due to the many factors inherent in model racecar competition, we

cannot guarantee any parts once you start racing the car. Products which have been worn out, abused, neglected or improperly operated will not be covered under warranty.

We wish you enjoyment of this high-quality and high-performance RC car and wish you best success on the track!

**In line with our policy of continuous product development, the exact specifications of the kit may vary. In the unlikely event of any problems with your new kit, you should contact the model shop where you purchased it, quoting the part number.**

**We do reserve all rights to change any specification without prior notice. All rights reserved.**

**X4F'25**



# TOOLS REQUIRED



## INCLUDED



## EQUIPMENT REQUIRED

<p>Transmitter</p>	<p>Receiver</p>	<p>Speed Controller</p>	<p>Steering Servo</p>
<p>Electric Motor</p>	<p>Pinion Gear with Setscrew</p>	<p>LiPo Battery</p>	<p>Battery Charger</p>
<p>Lexan™ Paint</p>	<p>Wheels &amp; Tires &amp; Inserts (HUDY #803041 SLICK PRECUT)</p>	<p>190mm Bodyshell</p>	<p>Double-sided Tape (HUDY #107875)</p>
<p>Fibre Tape (HUDY #107870)</p>	<p>Bearing Oil (HUDY #106230)</p>	<p>Threadlock</p>	<p>CA glue</p>



# BUILD TIPS & NOTES



Alexander Hagberg (Factory Driver)

When a QR CODE is found in the instruction manual, scan the code to be directed to an online video that explains that feature or adjustment in more detail. Make sure to watch all of the instructional videos to get the most performance out of your car.

VIDEO TECH TIP



NOTE!

Please note that the videos are made specifically for the X4, but will contain very good information that may apply to the X4F as well.



### SAMPLE OF OPTIONAL PARTS

OPTION	#30XXXX	TYPE1	OPTION
	#30XXXX	TYPE1	OPTION 1
	#30XXXX	TYPE1	OPTION 2
	#30XXXX	TYPE1	INCLUDED
	#30XXXX	TYPE1	OPTION 3

XRAY offers wide range of OPTIONAL tuning parts which are listed in a table like this. Please refer to the exploded view of each main section to verify which part is included in the kit while all other parts are available only as an optional part and must be purchased separately.

## COLOR INDICATIONS

At the beginning of each section is an exploded view of the parts to be assembled. There is also a list of all the parts and part numbers that are related to the assembly of that section.

The part descriptions are color-coded to make it easier for you to identify the source of a part. Here are what the different colors mean:

- 304911** **STYLE A** - indicates parts that are included in the bag marked for the section.
- 301021** **STYLE B** - indicates parts that are included in the box.
- 304902** **STYLE C** - indicates parts that are already assembled from previous steps.
- 301085** **STYLE D** - indicates parts that are optional.

## CHASSIS PREPARATION



VIDEO TECH TIP



CHASSIS PREPARATION

To protect and seal edges of graphite parts, sand edges smooth and then apply CA glue.

Do this for: chassis edges and countersunk holes.

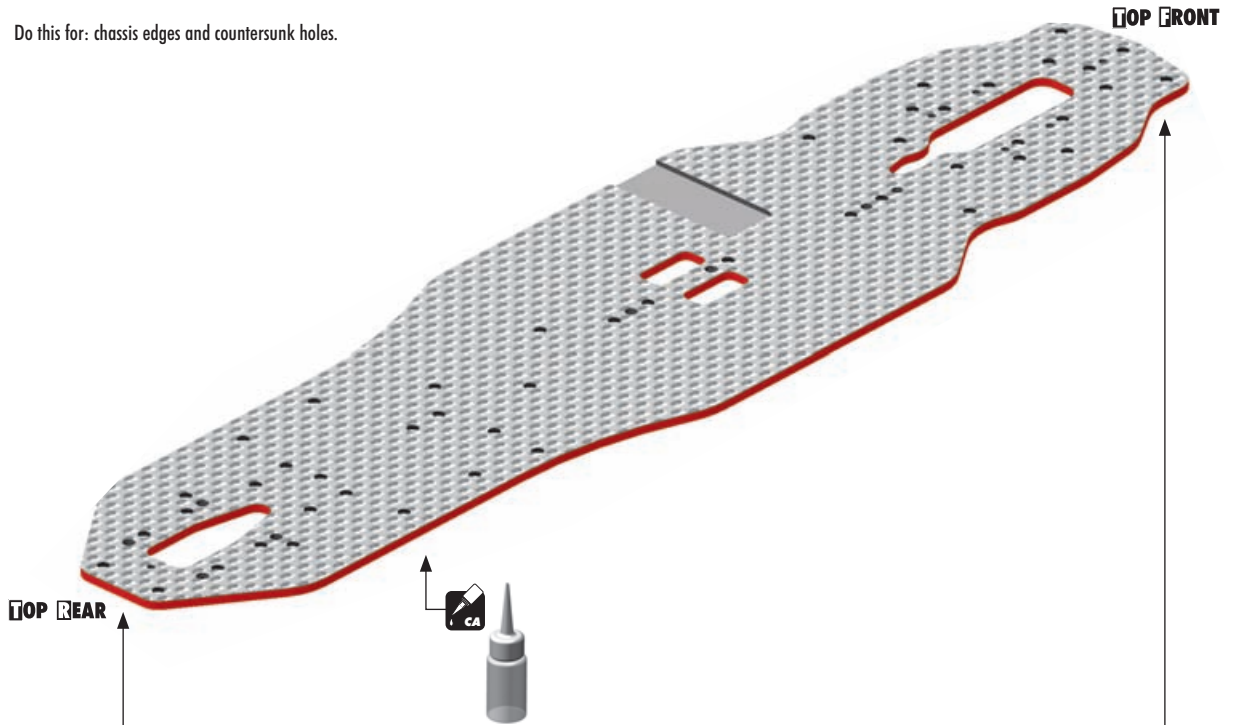

**TOP  
REAR**

Apply only a bit of CA glue in the countersunk holes.

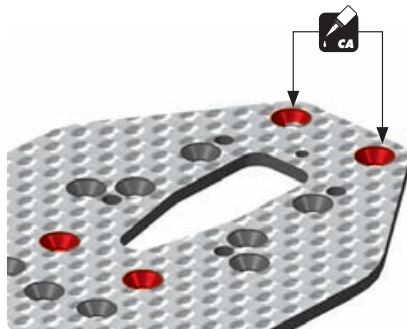

**TOP  
FRONT**

Apply only a bit of CA glue in the countersunk holes.

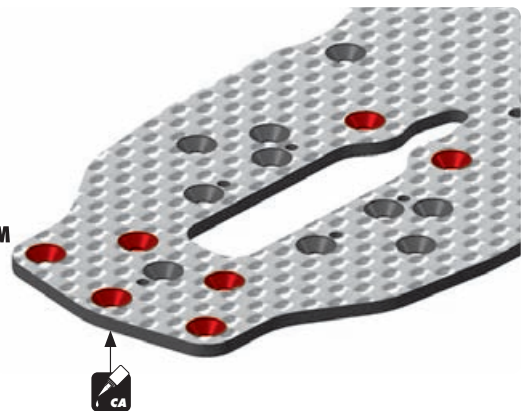

# 1. GEAR DIFFERENTIAL



#104002  
HUDY AIR VAC – VACUUM PUMP

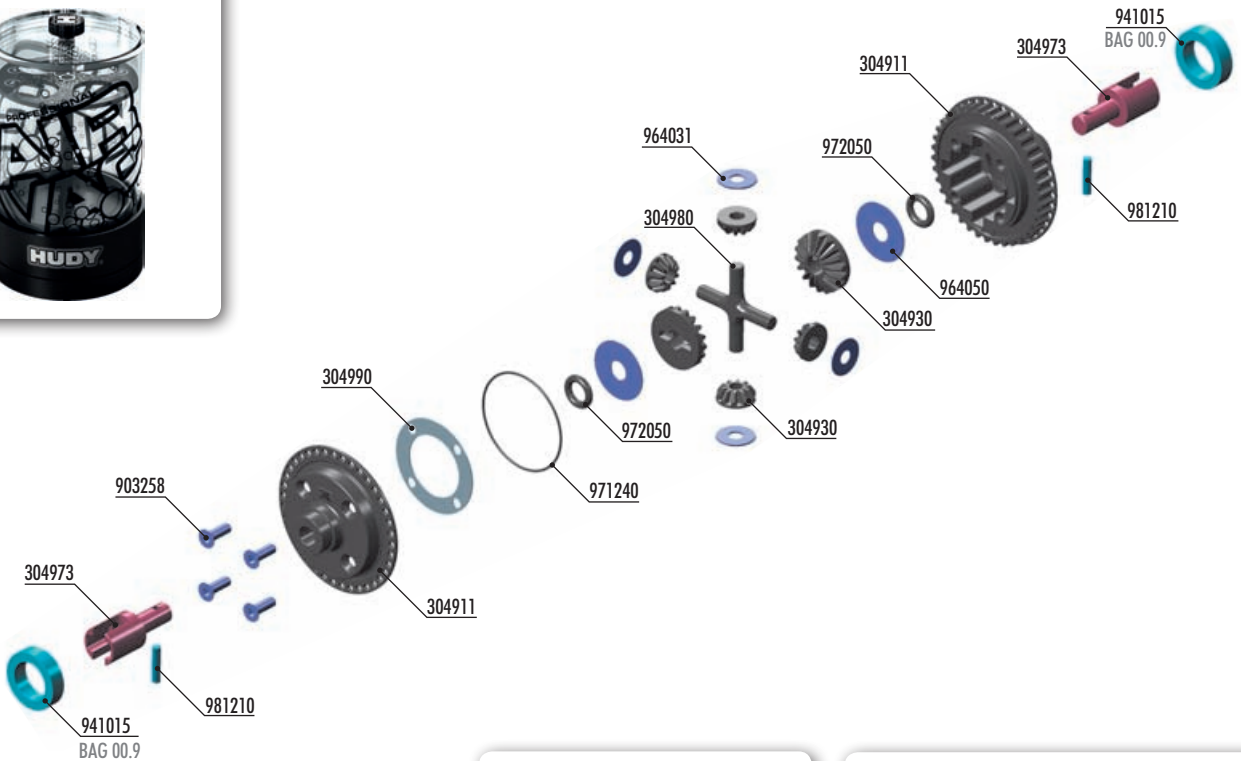

#304972  
ALU GEAR DIFF CVD BB DRIVESHAFT  
ADAPTER - SWISS 7075 T6 (2)



#304932  
GRAPHITE GEAR DIFF BEVEL & SATELLITE GEARS (2+4)



- 304902 X4 BB GEAR DIFFERENTIAL - SET
- 304911 X4 COMPOSITE GEAR DIFF CASE WITH 38T PULLEY & COVER
- 304930 COMPOSITE GEAR DIFF BEVEL & SATELLITE GEARS (2+4)
- 304973 STEEL GEAR DIFF BB DRIVESHAFT ADAPTER - HUDY SPRING STEEL™ (2)
- 304980 COMPOSITE GEAR DIFF CROSS PIN
- 304990 DIFF GASKET (4)

- 903258 HEX SCREW SFH M2.5x8 (10)
- 941015 BALL-BEARING 10x15x4 RUBBER SEALED - OIL (2)
- 964031 WASHER S 3.5x10x0.2 (10)
- 964050 WASHER S 5x15x0.3 (10)
- 971240 SILICONE O-RING 24x0.7 (10)
- 972050 SILICONE O-RING 5x2 (10)
- 981210 PIN 2x10 (10)

Numbers in parentheses ( ) refer to quantities when purchased separately.



1x 964050  
S 5x15x0.3



1x 972050  
O 5x2



1x 981210  
P 2x10

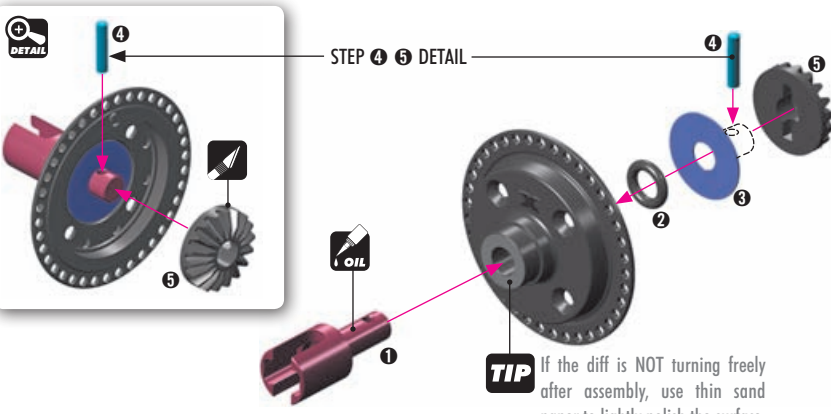

**TIP** If the diff is NOT turning freely after assembly, use thin sand paper to lightly polish the surface.





#304932  
GRAPHITE GEAR DIFF BEVEL  
& SATELLITE GEARS (2+4)



#304972  
ALU GEAR DIFF CVD BB DRIVESHAFT  
ADAPTER - SWISS 7075 T6 (2)



# 1. GEAR DIFFERENTIAL

-  1x 964050  
S 5x15x0.3
-  1x 972050  
O 5x2
-  1x 981210  
P 2x10

**NOTE ORIENTATION**

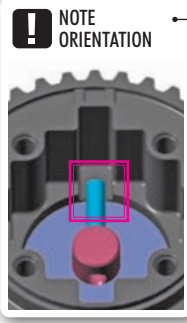

**STEP 4 DETAIL**  
Use tweezers to insert pin.

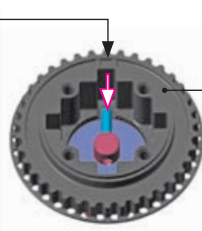

If the diff is NOT turning freely after assembly, use thin sand paper to lightly polish the surface.

**TIP**  **OIL**



**CUTAWAY VIEW**

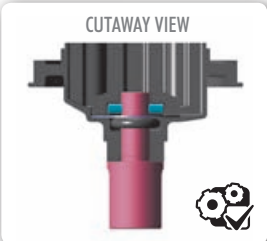

-  4x 964031  
S 3.5x10x0.2

**OPTION**  #304932  
GRAPHITE GEAR DIFF BEVEL & SATELLITE GEARS (2+4)



**!** If the cross does NOT enter into the diff freely, use fine sand paper to lightly polish the ends of the cross.

**(INITIAL SETTING)**  
500.000cSt



**TIP**  **OIL**

Fill differential up to the top of the diff pin.  
DO NOT fill the diff to the top of the housing.

TO ENSURE YOU HAVE THE SAME AMOUNT OF OIL FROM REBUILD TO REBUILD, DO THE FOLLOWING:



**VIDEO TECH TIP**



REAR DIFFERENTIAL



**1** Put the diff (without oil) on the scale and check the weight (approximately 12.00g)

**#107865**  
HUDY Ultimate Digital Pocket Scale 300g ± 0.01g

**2** Slowly pour oil into the diff and watch the weight. Add 1.50g of oil into the diff. The approximate weight of the diff including oil is 13.50g.

$12.00g + 1.50g = 13.50g$

**TIP** **TIPS FOR DIFFERENTIALS** **TIP**

100.000cSt (HUDY #106610)	Lower viscosity oil will increase steering but reduce traction.
150.000cSt (HUDY #106615)	
200.000cSt (HUDY #106620)	<b>LOWER VISCOSITY</b>
300.000cSt (HUDY #106630)	
500.000cSt (HUDY #106650) <b>INITIAL SETTING</b>	<b>HIGHER VISCOSITY</b>
1 000.000cSt (HUDY #106692)	
2 000.000cSt (HUDY #106694)	Higher viscosity oil will improve forward traction and increase stability, but reduces steering.

**TIP** To make sure that all the air is removed from the diff oil, we recommend using the HUDY Air Vac.



**OPTION**  #104002  
HUDY AIR VAC – VACUUM PUMP



# 1. GEAR DIFFERENTIAL

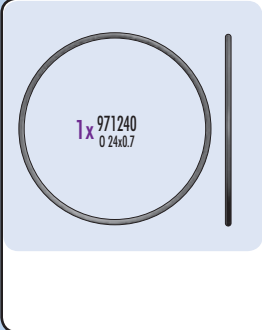

After disassembling the gear diff, the large O-ring may have an increased size and may be more difficult to re-install. We recommend either inserting the old O-ring carefully in the diff cover, or installing a new O-ring if the old one cannot be made to fit properly.

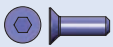

4x 903258  
SFH M2.5x8

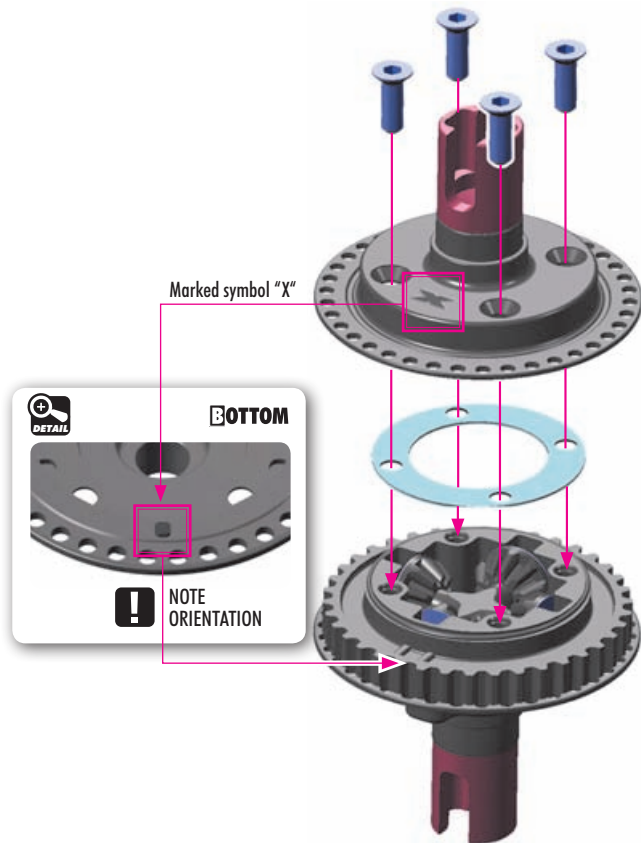

Tighten the screws equally but DO NOT tighten them completely.

Finish tightening in this order.

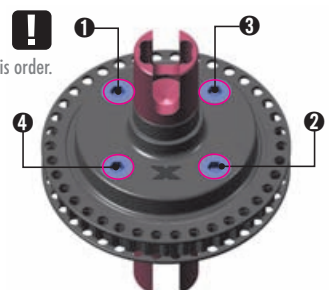

2x 941015  
BB 10x15x4

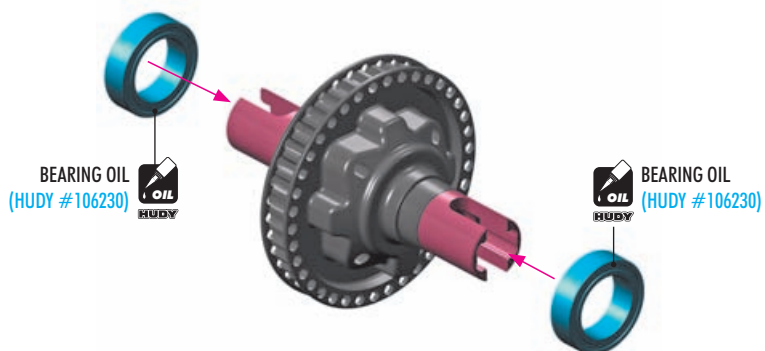

## 2. FRONT & REAR SUSPENSION

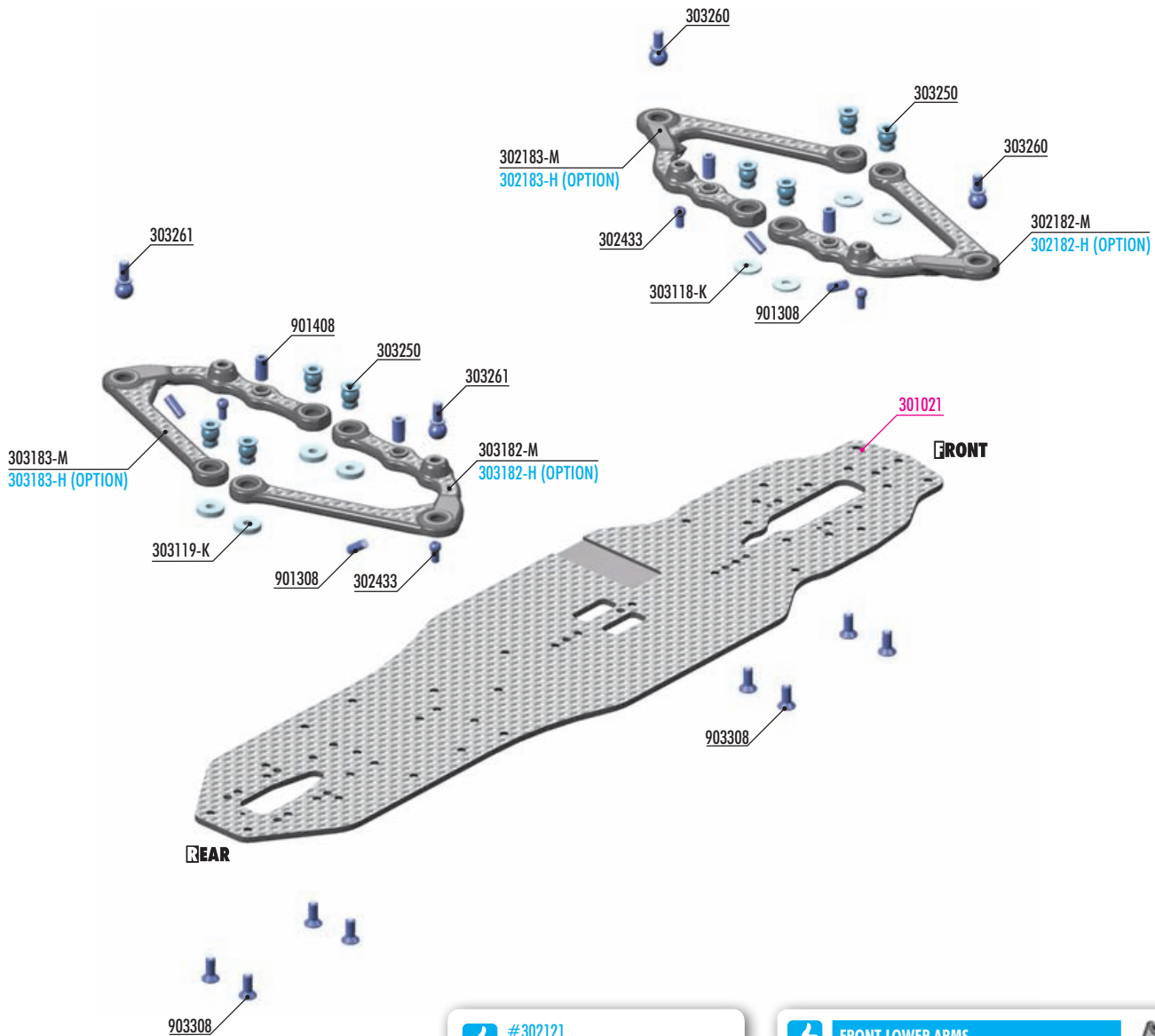

 #302121  
FRONT ROLL-CENTER SPACER (2)  
OPTION





 #302122  
REAR ROLL-CENTER SPACER (2)  
OPTION



 FRONT LOWER ARMS

#	POSITION	TYPE	INCLUDED
#302183-M	LEFT	MEDIUM	INCLUDED
#302182-M	RIGHT	MEDIUM	INCLUDED
#302183-H	LEFT	HARD	OPTION
#302182-H	RIGHT	HARD	OPTION



 REAR LOWER ARMS

#	POSITION	TYPE	INCLUDED
#303183-M	LEFT	MEDIUM	INCLUDED
#303182-M	RIGHT	MEDIUM	INCLUDED
#303183-H	LEFT	HARD	OPTION
#303182-H	RIGHT	HARD	OPTION



BAG

02

- 302182-M X4 CFF™ FRONT LOWER ARM - INNER SHOCK POSITION - MEDIUM - RIGHT
- 302183-M X4 CFF™ FRONT LOWER ARM - INNER SHOCK POSITION - MEDIUM - LEFT
- 302433 ANTI-ROLL BAR STEEL BALL END 3.8mm WITH 4mm THREAD (2)
- 303118-K ALU SHIM 3x9x1.0mm - BLACK (10)
- 303119-K ALU SHIM 3x9x2.0mm - BLACK (10)
- 303182-M X4 CFF™ REAR LOWER ARM - INNER SHOCK POSITION - MEDIUM - RIGHT
- 303183-M X4 CFF™ REAR LOWER ARM - INNER SHOCK POSITION - MEDIUM - LEFT
- 303250 X4 LOWER ARM BALL UNIVERSAL 6.0mm WITH HEX - HUDY SPRING STEEL™ (2)
- 303260 X4 PIVOT BALL 6.0mm WITH M3x5.5mm THREAD - HUDY SPRING STEEL™ (2)
- 303261 X4 PIVOT BALL 6.0mm WITH M3x6.5mm THREAD - HUDY SPRING STEEL™ (2)

- 901308 HEX SCREW SB M3x8 (10)
- 901408 HEX SCREW SB M4x8 (10)
- 903308 HEX SCREW SFH M3x8 (10)

301021 X4F'25 GRAPHITE CHASSIS 2.2MM

## 2. FRONT & REAR SUSPENSION

### REAR SUSPENSION ARMS

**NOTE ORIENTATION** (multiple instances)

**6.5mm THREAD**

**Remove the pins.** →

**PRESS POSITION**

**Press straight**

To make sure that the pivot ball is pressed into the arm correctly, remove the pins from the HUDY Multi Tool and use the exact press position like shown on the picture. This way the ball will never go through the arm and will NOT create any excessive play.

- 2x 901308 SB M3x8
- 2x 901408 SB M4x8

**VIDEO TECH TIP**

LOWER ARMS

### REAR SUSPENSION ARMS

**4x8mm**

**3x8mm**

**2.6mm**

**4.0mm**

**Make sure to NOT OVERTIGHTEN** (multiple instances)

**TIP** Install the pivot balls with Professional Multi Tool (HUDY #183011).

**LEFT = RIGHT**

### FRONT SUSPENSION ARMS

**NOTE ORIENTATION** (multiple instances)

**5.5mm THREAD**

**Remove the pins.** →

**PRESS POSITION**

**Press straight**

To make sure that the pivot ball is pressed into the arm correctly, remove the pins from the HUDY Multi Tool and use the exact press position like shown on the picture. This way the ball will never go through the arm and will NOT create any excessive play.



## 2. FRONT & REAR SUSPENSION



2x 901308  
SB M3x8



2x 901408  
SB M4x8

### FRONT SUSPENSION ARMS

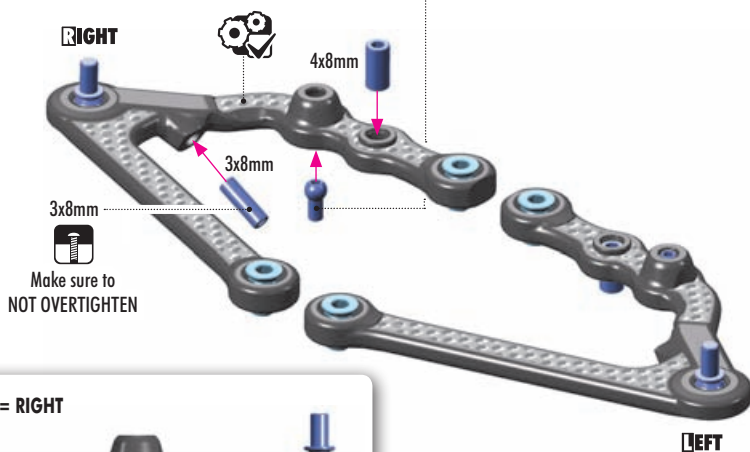

**TIP** Install the pivot balls with Professional Multi Tool (HUDY #183011).

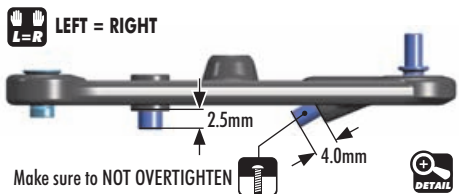
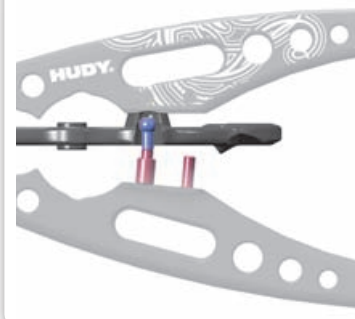

4x 303118-K  
SHIM 3x9x1

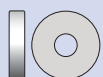

4x 303119-K  
SHIM 3x9x2



8x 903308  
SFH M3x8

**#302121**  
FRONT ROLL-CENTER SPACER (2)



**#302122**  
REAR ROLL-CENTER SPACER (2)

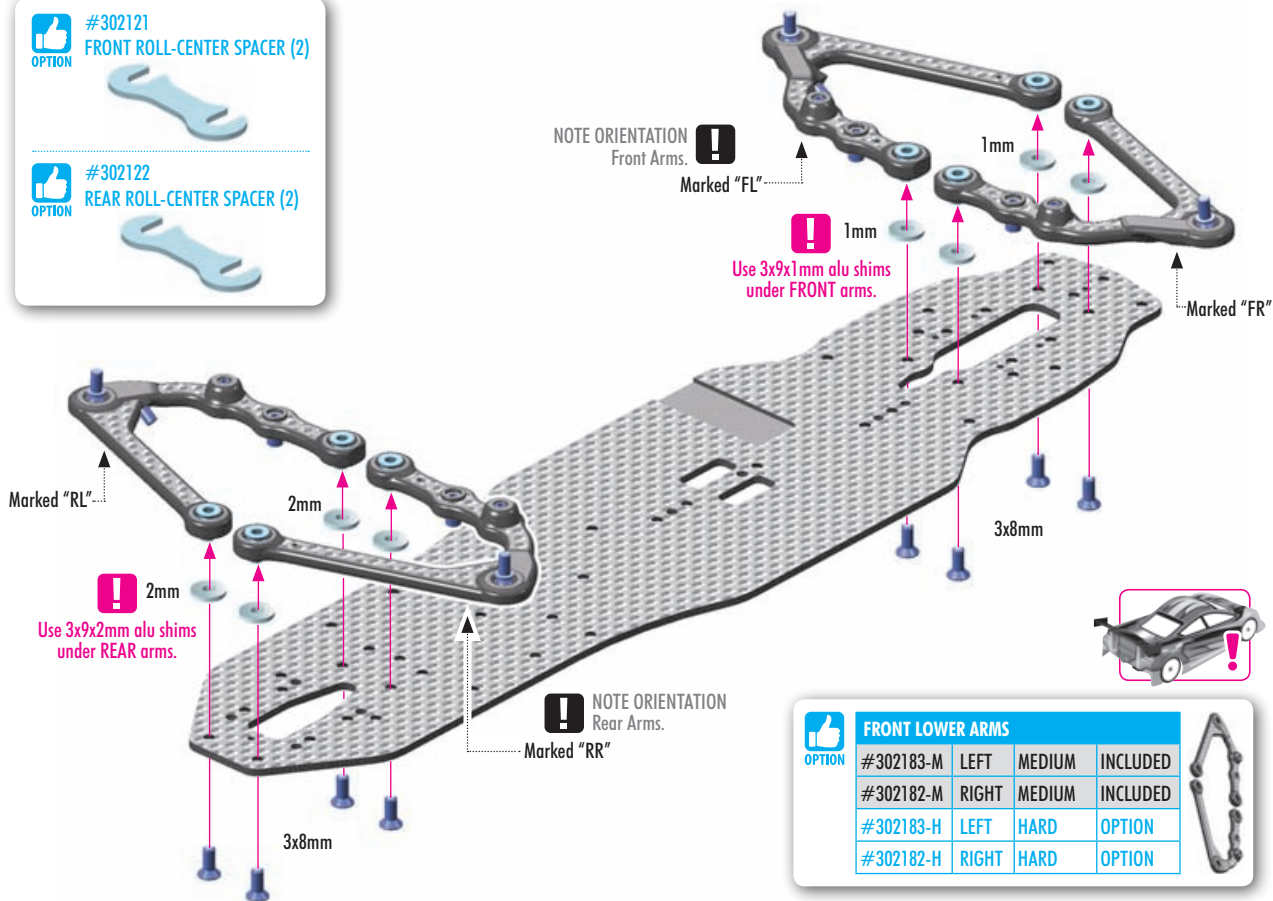

OPTION	FRONT LOWER ARMS			
#302183-M	LEFT	MEDIUM	INCLUDED	
#302182-M	RIGHT	MEDIUM	INCLUDED	
#302183-H	LEFT	HARD	OPTION	
#302182-H	RIGHT	HARD	OPTION	

OPTION	REAR LOWER ARMS		
#303183-M	LEFT	MEDIUM	INCLUDED
#303182-M	RIGHT	MEDIUM	INCLUDED
#303183-H	LEFT	HARD	OPTION
#303182-H	RIGHT	HARD	OPTION

### ROLL-CENTER ADJUSTMENT

**RAISING THE LOWER ARMS** will raise the car's roll center. Raising the lower arms both front and rear will free up the car, and will make it initially more responsive. Side bite will be decreased. A higher roll center is typically recommended for asphalt racing.

**LOWERING THE LOWER ARMS** will lower the car's roll center. Lowering both the front and rear arms will lock in the car more, and will make it initially less responsive. Side bite will be increased. A lower roll center is typically recommended for carpet racing.

We recommend the **MEDIUM** hardness of the lower suspension arms for asphalt. These arms are more flexible than the H (hard) arms.

For carpet racing and even some high-grip asphalt conditions, we recommend the **HARD** suspension arms.



VIDEO TECH TIP



ROLL-CENTER



CHASSIS ALTERNATIVES

# 3. CENTRAL TRANSMISSION

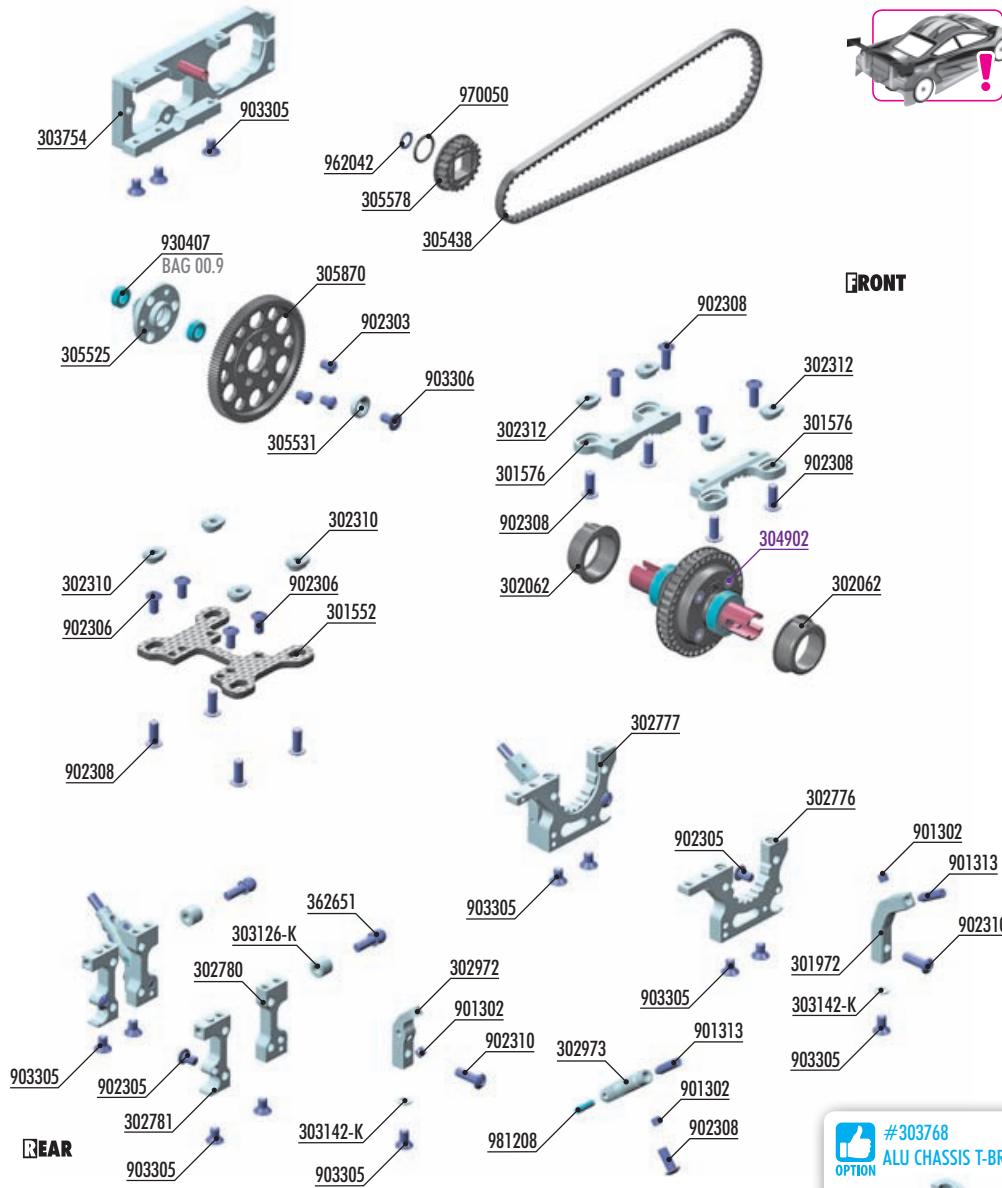

**#301578**  
ALU UPPER CLAMPS - 1.0mm  
OPTION

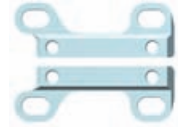

**FRONT**

**OPTION**

### SPUR GEARS 48P

#305772	72T / 48P	OPTION
#305776	76T / 48P	OPTION
#305778	78T / 48P	OPTION
#305779	79T / 48P	OPTION
#305781	81T / 48P	OPTION
#305784	84T / 48P	OPTION
#305784-0	84T / 48P	OPTION

### OFFSET SPUR GEARS 64P

#305860	90T / 64P	OPTION
#305862	92T / 64P	OPTION
#305866	96T / 64P	OPTION
#305866-0	96T / 64P	OPTION
#305869	99T / 64P	OPTION
#305870	100T / 64P	INCLUDED
#305870-0	100T / 64P	OPTION
#305874	104T / 64P	OPTION
#305876	106T / 64P	OPTION
#305878	108T / 64P	OPTION
#305880	110T / 64P	OPTION
#305880-0	110T / 64P	OPTION
#305882	112T / 64P	OPTION
#305884	114T / 64P	OPTION

**OPTION**

**#303768**

ALU CHASSIS T-BRACE - 7075 T6  
OPTION



**OPTION**

**#303767**

BRASS CHASSIS T-BRACE - 8g  
OPTION



**OPTION**

### ALU CASTER BUSHINGS

#302310	FRONT 3° / REAR 5.5° or 0.5°	1 Dot	INCLUDED
#302311	FRONT 4° / REAR 4.5° or 1.5°	2 Dots	OPTION
#302312	FRONT 5° / REAR 3.5° or 2.5°	3 Dots	INCLUDED

**OPTION**

**#305578-0**  
FIXED PULLEY FOR LAYSHAFT WITH BEARINGS 20T - GRAPHITE (2)



**OPTION**

**#302064-K**  
ALU ADJ. BALL-BEARING HUB +1MM (2)



**OPTION**

**#302063-K**  
ALU ADJUSTMENT BALL-BEARING HUB (2)



**BAG**  
03

- 301552 X4F GRAPHITE REAR UPPER CLAMP
- 301576 ALU UPPER CLAMP - INNER SHOCK POSITION - SWISS 7075 T6 (L+R)
- 301972 ALU SHOCK HOLDER FRONT FIXED - SWISS 7075 T6 (2)
- 302062 COMPOSITE ADJUSTMENT BALL-BEARING HUB (4)
- 302310 ALU CASTER BUSHING FRONT 3° / REAR 0.5°/5.5° - 1 DOT (4)
- 302312 ALU CASTER BUSHING FRONT 5° / REAR 2.5°/3.5° - 3 DOTS (4)
- 302776 ALU LOWER BULKHEAD - FRONT RIGHT - 7075 T6
- 302777 ALU LOWER BULKHEAD - FRONT LEFT - 7075 T6
- 302780 X4F ALU REAR BULKHEAD - FRONT - SWISS 7075 T6
- 302781 X4F ALU REAR BULKHEAD - REAR - SWISS 7075 T6
- 302972 ALU SHOCK HOLDER REAR FIXED - SWISS 7075 T6 (2)
- 302973 ALU SHOCK HOLDER REAR ACTIVE - SWISS 7075 T6 (2)
- 303126-K ALU SHIM 3x6x5.0mm - BLACK (10)
- 303142-K ALU SHIM 3x5x0.5mm - BLACK (10)
- 303754 X4F ALU MOTOR MOUNT - SWISS 7075 T6
- 305438 HIGH-PERFORMANCE DRIVE BELT 3 x 291mm
- 305525 X4F ALU SOLID LAYSHAFT & BEARINGS
- 305531 X4F ALU SOLID LAYSHAFT WASHER FOR BATTERY BACKSTOP

- 305578 FIXED PULLEY FOR LAYSHAFT WITH BEARINGS 20T (2)
- 305870 OFFSET SPUR GEAR 100T / 64
- 362651 BALL END 4.9MM WITH THREAD 8mm (2)
- 901302 HEX SCREW SB M3x2.5 (10)
- 901313 HEX SCREW SB M3x12 (10)
- 902303 HEX SCREW SH M3x4 SMALL HEAD - STAINLESS (10)
- 902305 HEX SCREW SH M3x5 (10)
- 902306 HEX SCREW SH M3x6 (10)
- 902308 HEX SCREW SH M3x8 (10)
- 902310 HEX SCREW SH M3x10 (10)
- 903305 HEX SCREW SFH M3x5 (10)
- 903306 HEX SCREW SFH M3x6 (10)
- 930407 BALL-BEARING 4x7x2.5 STEEL SEALED - OIL (2)
- 962042 WASHER S 4x6x0.1 (10)
- 970050 O-RING 5x1 (10)
- 981208 PIN 2x8 (10)
- 304902 X4 BB GEAR DIFFERENTIAL - SET

Numbers in parentheses ( ) refer to quantities when purchased separately.

**XRAY**

# 3. CENTRAL TRANSMISSION



2x 303126-K SHIM 3x6x5



4x 902305 SH M3x5



8x 903305 SFH M3x5

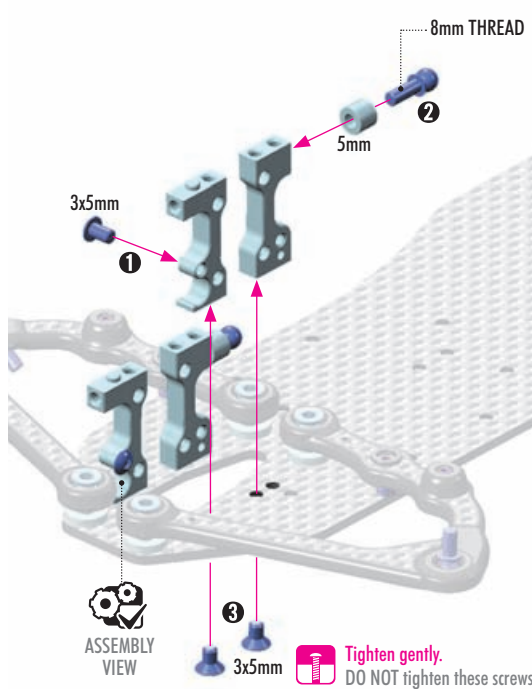
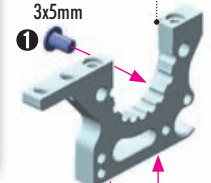
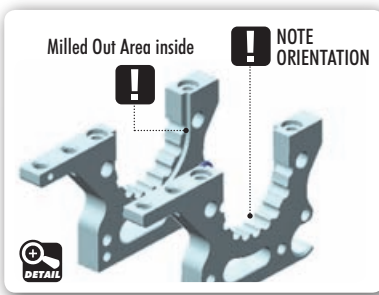

VIDEO TECH TIP



BUILDING THE BULKHEADS

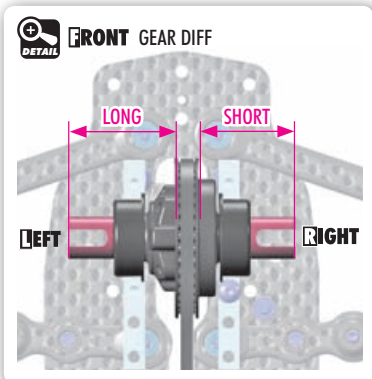

These +1mm hubs allow for extra high or extra low diff position compared to the kit eccentric parts. The extra high position improves rotation while extra low position improves traction.

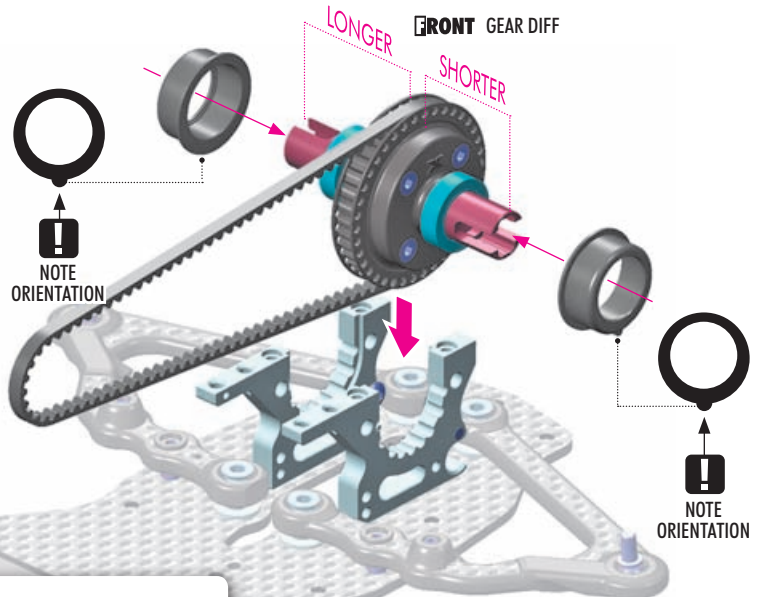



# 3. CENTRAL TRANSMISSION



**NOTE ORIENTATION FOR ALL PARTS**

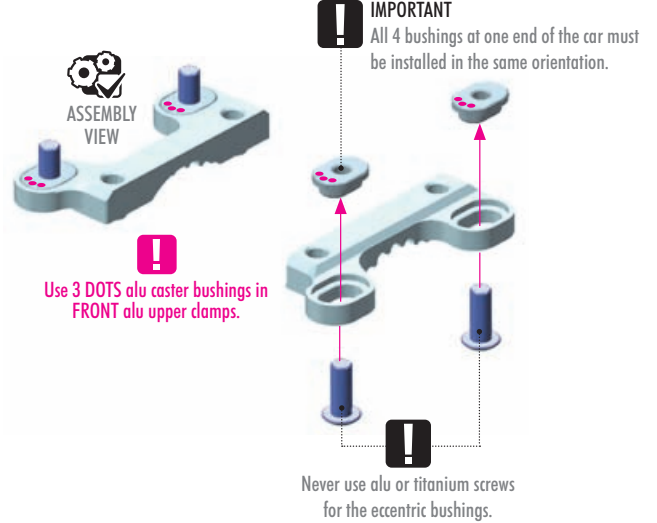
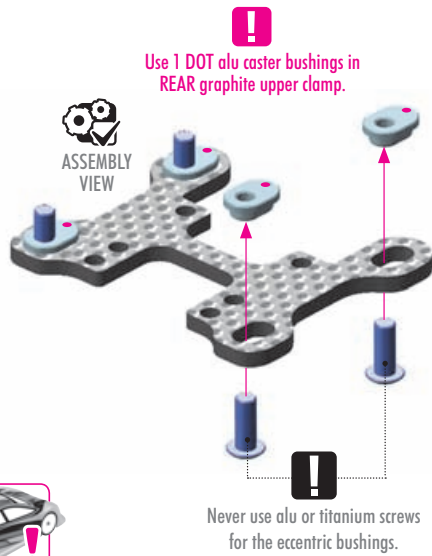

OPTION	ALU CASTER BUSHINGS			
#302310	FRONT 3° / REAR 5.5° or 0.5°	1 Dot	INCLUDED	
#302311	FRONT 4° / REAR 4.5° or 1.5°	2 Dots	OPTION	
#302312	FRONT 5° / REAR 3.5° or 2.5°	3 Dots	INCLUDED	



The new upper clamps move the inner pivot 1.0mm closer to center. This position lengthens the upper arm and reduces camber gain to free up the car. Mid corner steering improves in long sweepers, and traction rolling is reduced in very high traction carpet conditions. Recommended for large open tracks or high traction carpet tracks.

## CASTER ADJUSTMENT

### FRONT CASTER

For most conditions, 5.0 deg front caster is a good starting point. Decreasing caster increases entry steering but will cause more on-power push.

### REAR CASTER

A good starting point for rear caster is 0.5°.

0.5 caster generates more cornerspeed and makes the car easier to drive in long sweepers. Recommended for both carpet and asphalt tracks.

5.5 caster improves rotation and steering, mainly recommended for tight tracks.

IMPORTANT: All 4 bushings at one end of the car must be installed in the same orientation.

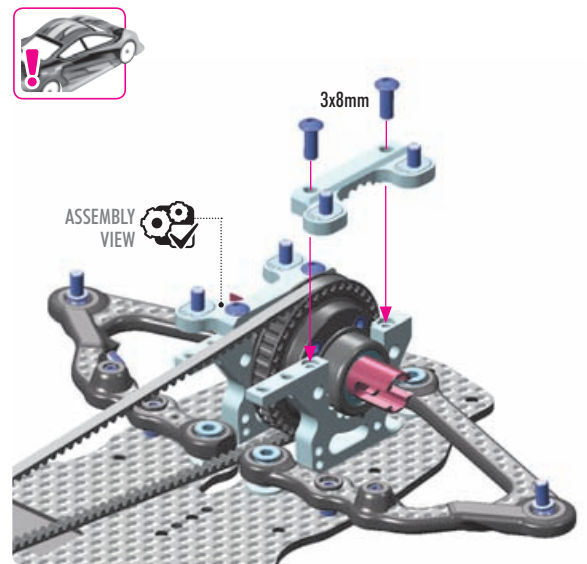
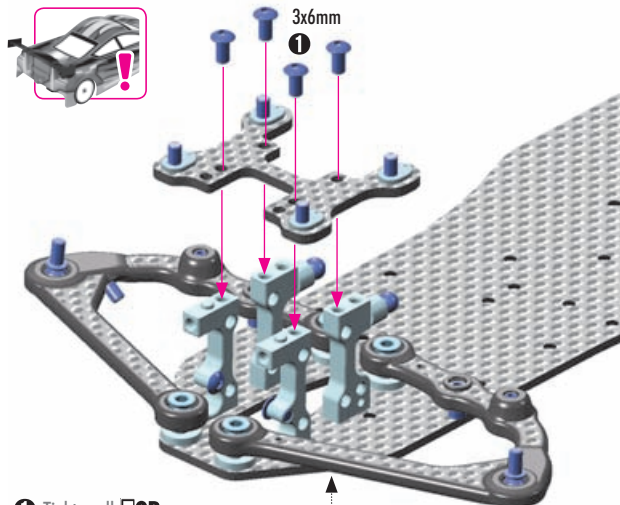
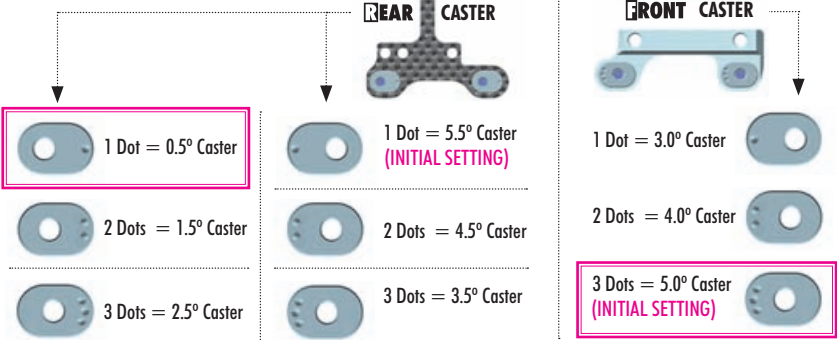

# 3. CENTRAL TRANSMISSION



## FRONT BELT TENSION ADJUSTMENT

Front diff **UPPER** position - tab in bottom notch - provides **more steering**, but **less front traction**

Front diff **LOWER** position - tab in top notch - provides **more front traction**, but makes the car **push on-power**.

Recommended for **medium-high** traction tracks and technical tracks.

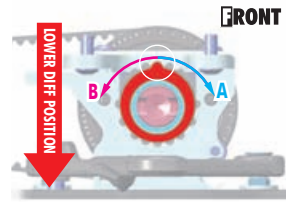
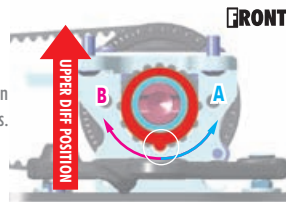

Recommended for **low-traction** tracks.

### INITIAL POSITION FOR CARPET/ASPHALT

Place tab in this **BOTTOM NOTCH**

**TO LOOSEN REAR BELT:** Rotate both front nylon hubs in arrow direction **A**  
**TO TIGHTEN REAR BELT:** Rotate both front nylon hubs in arrow direction **B**



VIDEO TECH TIP



DIFF HEIGHT



BELT TENSION ADJUSTMENT



3x 902303 SH M3x4



2x 930407 BB 4x7x2.5



1x 970050 O 5x1



1x 966081 CH-CLIP 8

1.

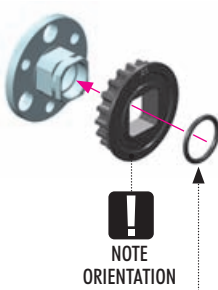

NOTE ORIENTATION

#966081 CH-CLIP 8 (10) INCLUDED IN THE LAST AID BAG

Another alternative to secure the pulley on the layshaft is to use the CH-clip which is included in the "Last Aid" Bag. To mount the clip on the layshaft, you have to use special Snap Ring Pliers.



#305578-0 FIXED PULLEY FOR LAYSHAFT WITH BEARINGS 20T GRAPHITE (2)



2. ALTERNATIVE 64P OFFSET SPUR GEAR (INITIAL SETTING)

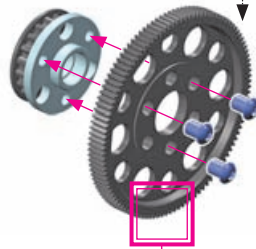

NOTE ORIENTATION



CUTAWAY VIEW

OFFSET NOTE ORIENTATION

OFFSET SPUR GEARS 64P			
#305860	90T	OPTION	
#305862	92T	OPTION	
#305866	96T	OPTION	
#305866-0	96T	OPTION	
#305869	99T	OPTION	
#305870	100T	INCLUDED	
#305870-0	100T	OPTION	
#305874	104T	OPTION	
#305876	106T	OPTION	
#305878	108T	OPTION	
#305880	110T	OPTION	
#305880-0	110T	OPTION	
#305882	112T	OPTION	
#305884	114T	OPTION	

2. ALTERNATIVE 48P SPUR GEAR

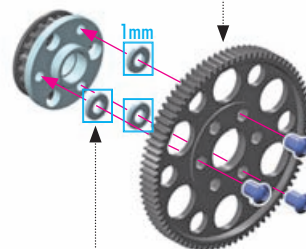

When using XRAY 48P spur gears or aftermarket spur gears without an offset, use the 3x5x1mm shims (#303141 NOT included) between the gear and layshaft to create the necessary clearance from the top deck.

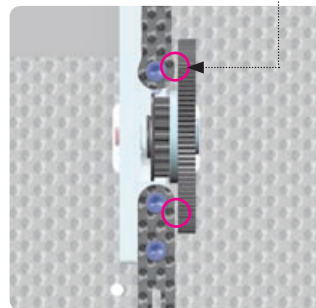

SPUR GEARS 48P			
#305772	72T	OPTION	
#305776	76T	OPTION	
#305778	78T	OPTION	
#305779	79T	OPTION	
#305781	81T	OPTION	
#305784	84T	OPTION	
#305784-0	84T	OPTION	

3.



BEARING OIL (HUDY #106230)



# 3. CENTRAL TRANSMISSION



1x 903306 SFH M3x6



1x 962042 S 4x6x0.1



VIDEO TECH TIP



BELT TENSION ADJUSTMENT

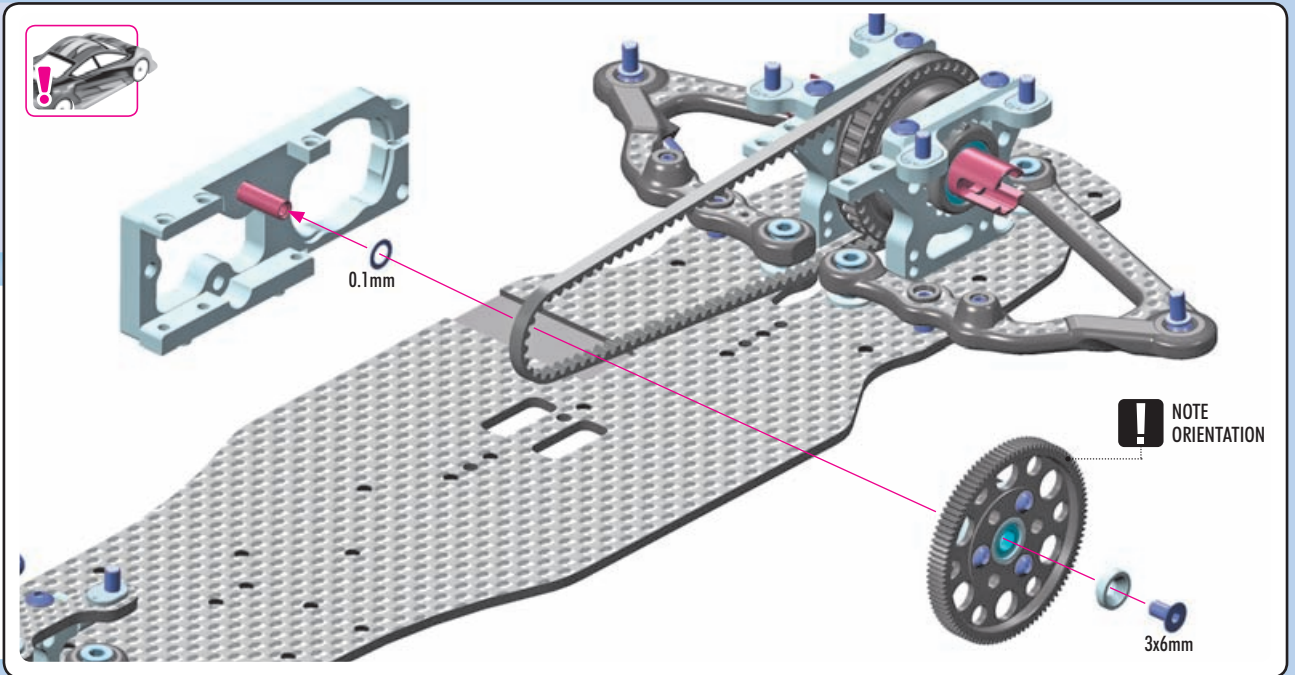

3x 903305 SFH M3x5

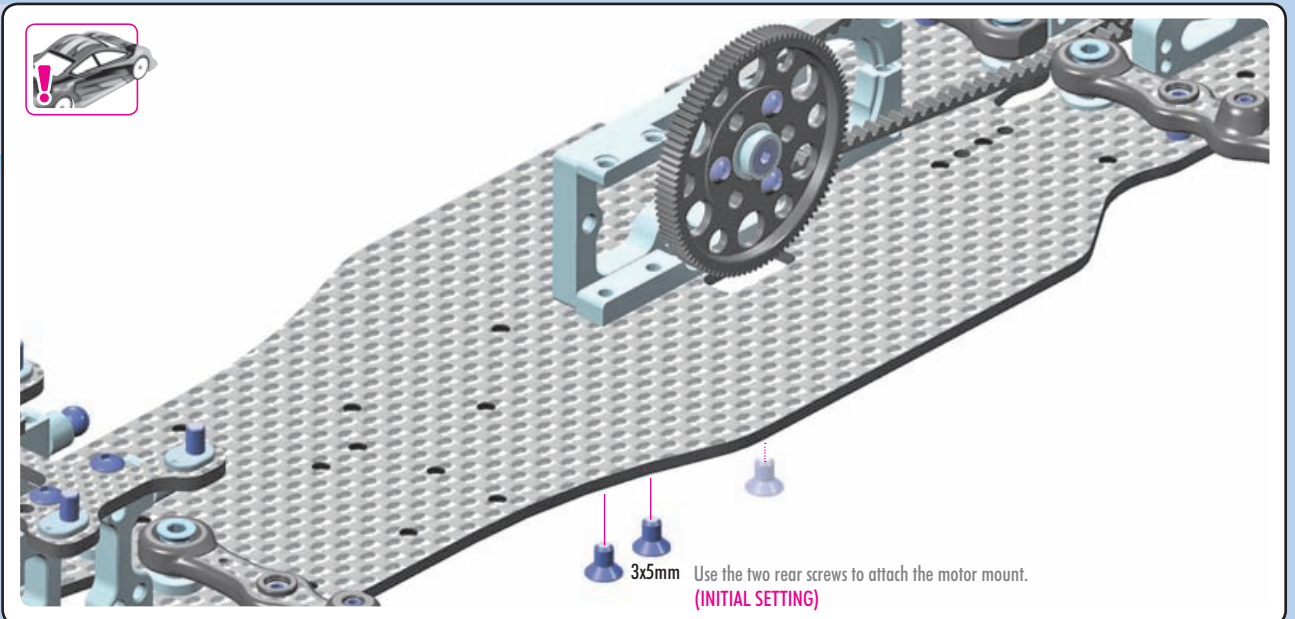

## MOTOR MOUNT FLEX ADJUSTMENT

### SOFT

Use only the rearmost screw to attach the motor mount as shown below. This allows more central chassis flex and will improve traction, especially on power. Rear grip will improve through the entire corner. This setting is recommended for low to medium traction conditions, both on asphalt and carpet.

REAR

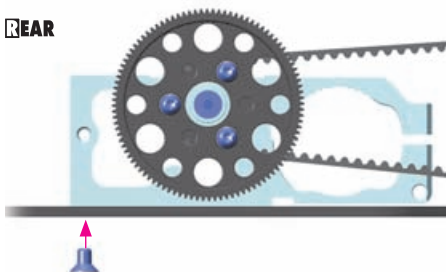

### MEDIUM (INITIAL SETTING)

Use the two rear screws to attach the motor mount as shown, and DO NOT install the very front screw. This configuration is a compromise between stability and initial response. The additional rear screw improves stability with a slight reduction in steering.

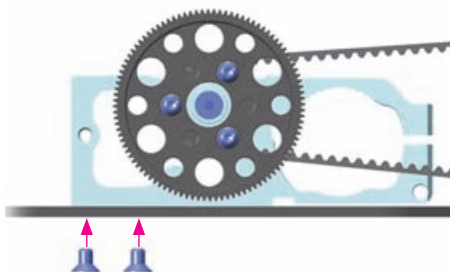

### STIFF

Use all three screws to attach the motor mount for maximum stability. Recommended for high traction surfaces.

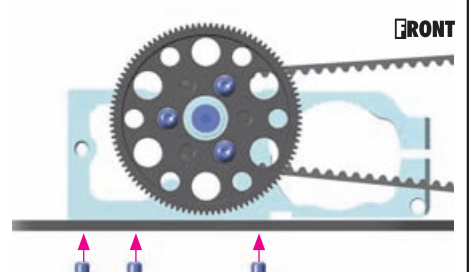

FRONT



# 3. CENTRAL TRANSMISSION

## OPTION



2x 303121-K  
SHIM 3x6x0.5



3x 903305  
SFH M3x5



2x 903306  
SFH M3x6

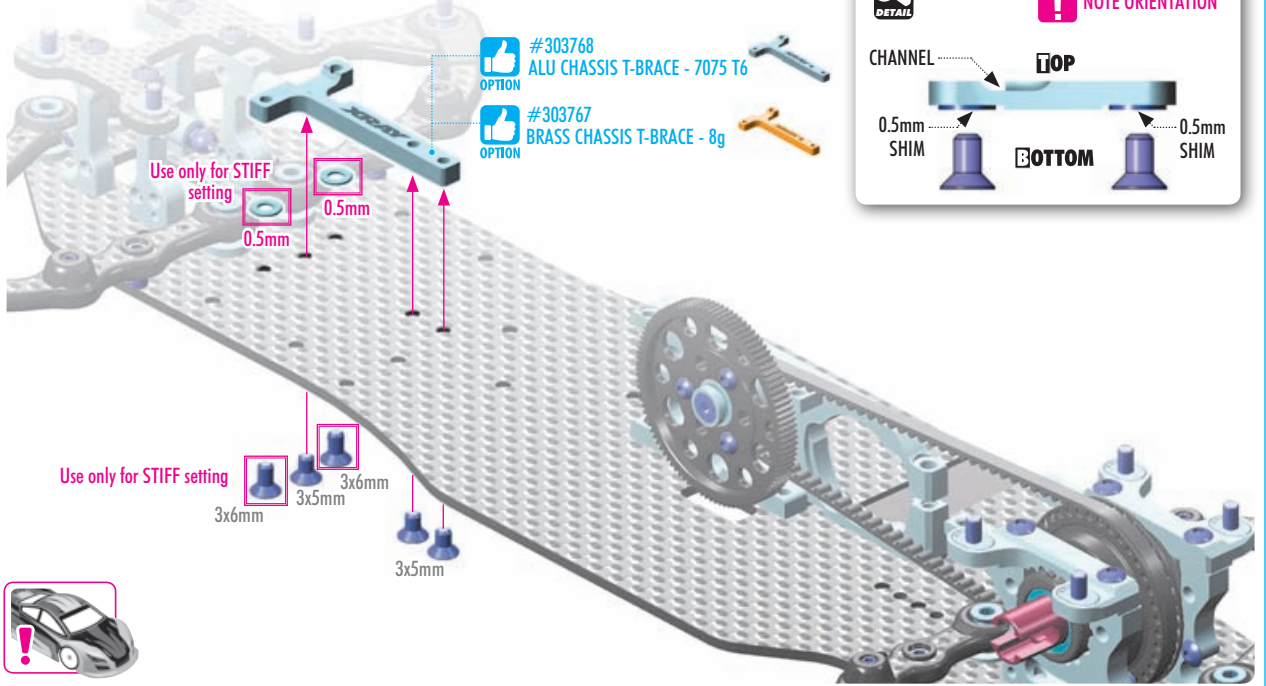

### CHASSIS FLEX ADJUSTMENT

The brace provides chassis flex adjustment possibilities depending on which screws are connected.

#### SOFT - NO BRACE

When the brace is NOT installed, the car will have the most steering and rotation. However, the car will be more difficult to drive as it is less stable. Recommended for medium-high traction conditions and for small, technical tracks with many hairpin corners.

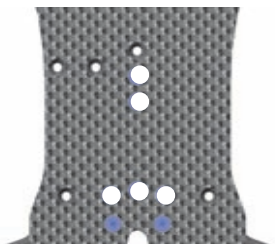

REAR

#### SOFT - MEDIUM

Install the brace using only the 2 forward bottom centerline screws (as shown). This gives improved on-power stability but still offers great off-power steering and rotation. Recommended for medium-high traction conditions and for small, technical tracks with many hairpin corners.

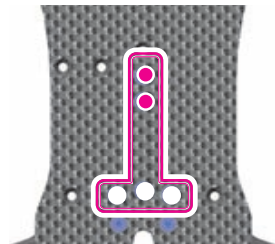

REAR

#### MEDIUM

Install the brace using all 3 bottom centerline screws (as shown). This gives improved on-power stability and traction, but makes the car push more off-power. Recommended for low- or high-traction conditions where stability and traction is needed.

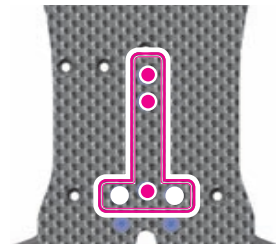

REAR

#### STIFF

In addition to installing all 3 bottom centerline screws, install the 2 side screws using 0.5mm shims between the brace and chassis. This setting gives maximum stability.

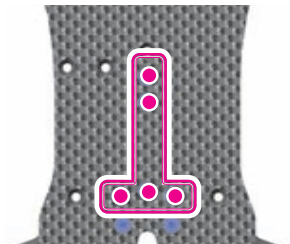

REAR

2x



2x 901302  
SB M3x2.5



2x 901313  
SB M3x12

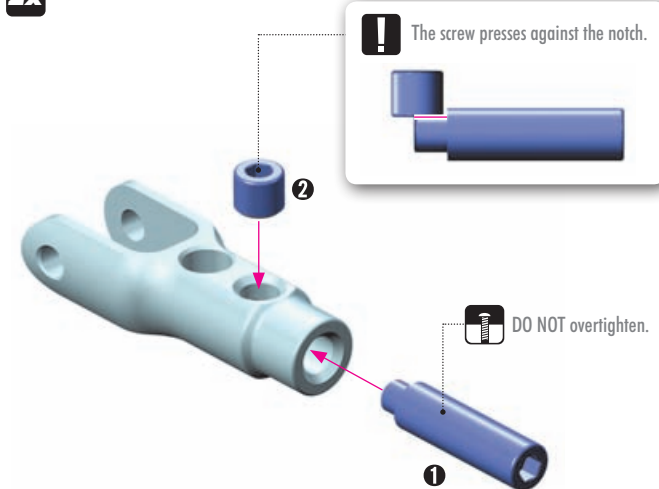

ASSEMBLY VIEW

# 3. CENTRAL TRANSMISSION

2x 901302  
SB M3x2.5

2x 981208  
P 2x8

## 2x REAR SHOCK HOLDERS

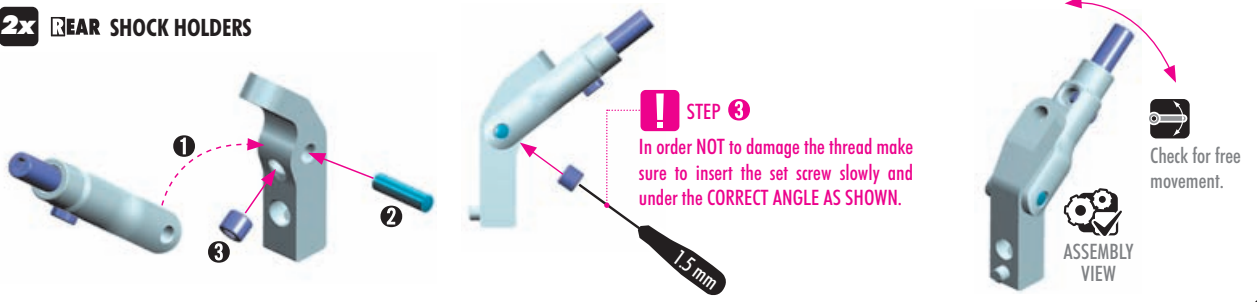

902308  
SH M3x8

### ALTERNATIVE 1.

#### FIXED REAR SHOCK HOLDERS (INITIAL SETTING)

Fixed rear shock holder setting provides traditional feel and suspension reaction and is the suggested starting point for most conditions.

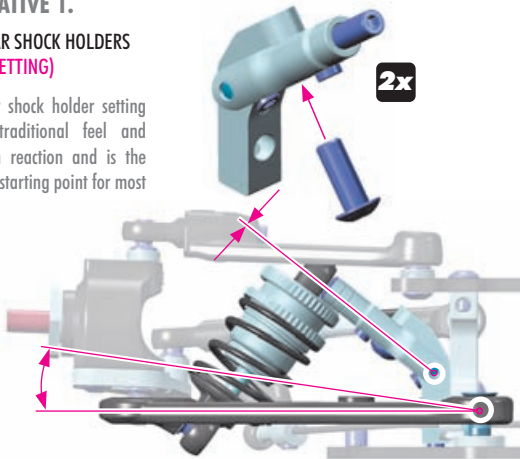

### ALTERNATIVE 2.

#### ACTIVE REAR SHOCK HOLDERS

Active rear shock holder setting increases speed of suspension reaction, improving off-power steering and rotation in high traction conditions.

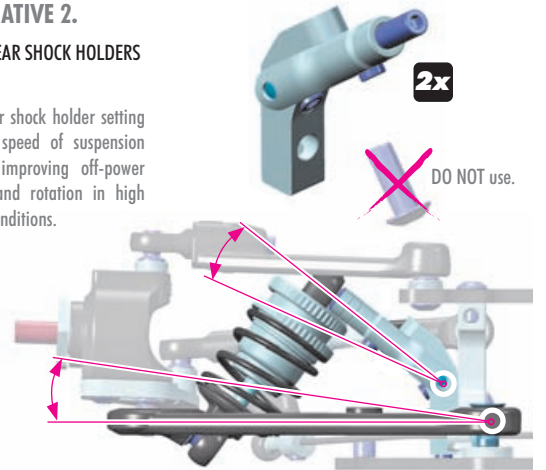

2x 303142-K  
SHIM 3x5x0.5

2x 902310  
SH M3x10

2x 903305  
SFH M3x5

## REAR SHOCK HOLDERS FLEX ADJUSTMENT

The brace provides chassis flex adjustment possibilities depending on which screws are connected.

### FLEX ALTERNATIVE 1. (INITIAL SETTING)

Attach the shock holder to both the chassis and bulkhead for free yet predictable handling for the easiest control. Recommended as a starting point for all traction levels.

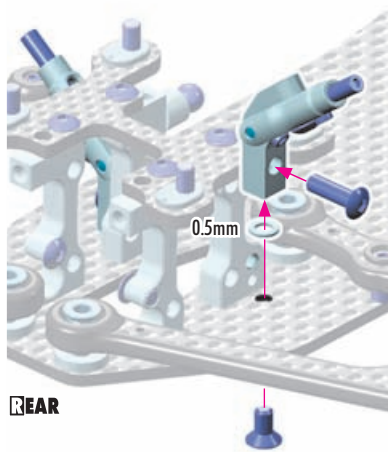

### FLEX ALTERNATIVE 2.

Attach the shock holder to only the chassis for medium flex setting. Provides more traction and steering than stiff setting. Recommended for medium traction tracks.

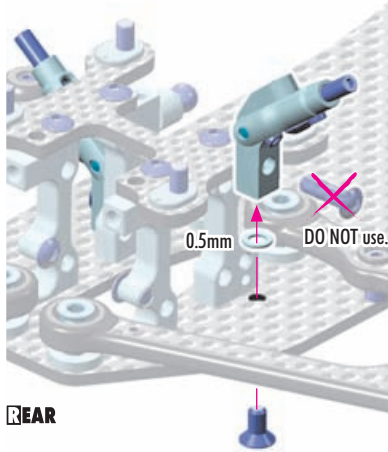

### FLEX ALTERNATIVE 3.

Attaching the shock holders to only the bulkheads generates maximum traction and steering and is recommended for lower traction conditions. It can make the car less stable and can lead to traction-roll in higher traction conditions.

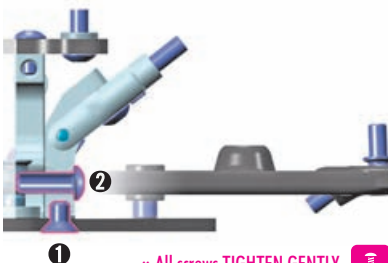
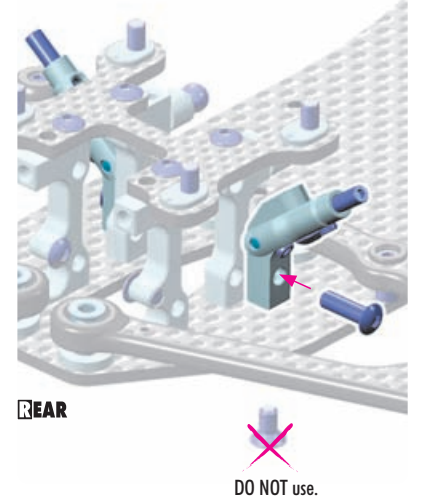

» All screws **TIGHTEN GENTLY**  
» Fully **TIGHTEN** in this order



# 3. CENTRAL TRANSMISSION

- 2x 901302 SB M3x2.5
- 2x 901313 SB M3x12

## 2x FRONT SHOCK HOLDERS

ASSEMBLY VIEW

DO NOT overtighten.

The screw presses against the notch.

6mm

- 2x 303142-K SHIM 3x5x0.5
- 2x 902310 SH M3x10
- 2x 903305 SFH M3x5

## FRONT SHOCK HOLDERS FLEX ADJUSTMENT

The brace provides chassis flex adjustment possibilities depending on which screws are connected.

### FLEX ALTERNATIVE 1. (INITIAL SETTING)

Attach the shock holder to both the chassis and bulkhead for free yet predictable handling for the easiest control. Recommended as a starting point for all grip levels.

### FLEX ALTERNATIVE 2.

Attach the shock holder to only the chassis for medium flex setting. Provides more traction and steering than stiff setting. Recommended for medium traction tracks.

### FLEX ALTERNATIVE 3.

Attaching the shock holders to only the bulkheads generates maximum traction and steering and is recommended for lower traction conditions. It can make the car less stable and can lead to traction-roll in higher traction conditions.

1 » All screws **TIGHTEN GENTLY**

2 » Fully **TIGHTEN** in this order 1 2



# 4. STEERING

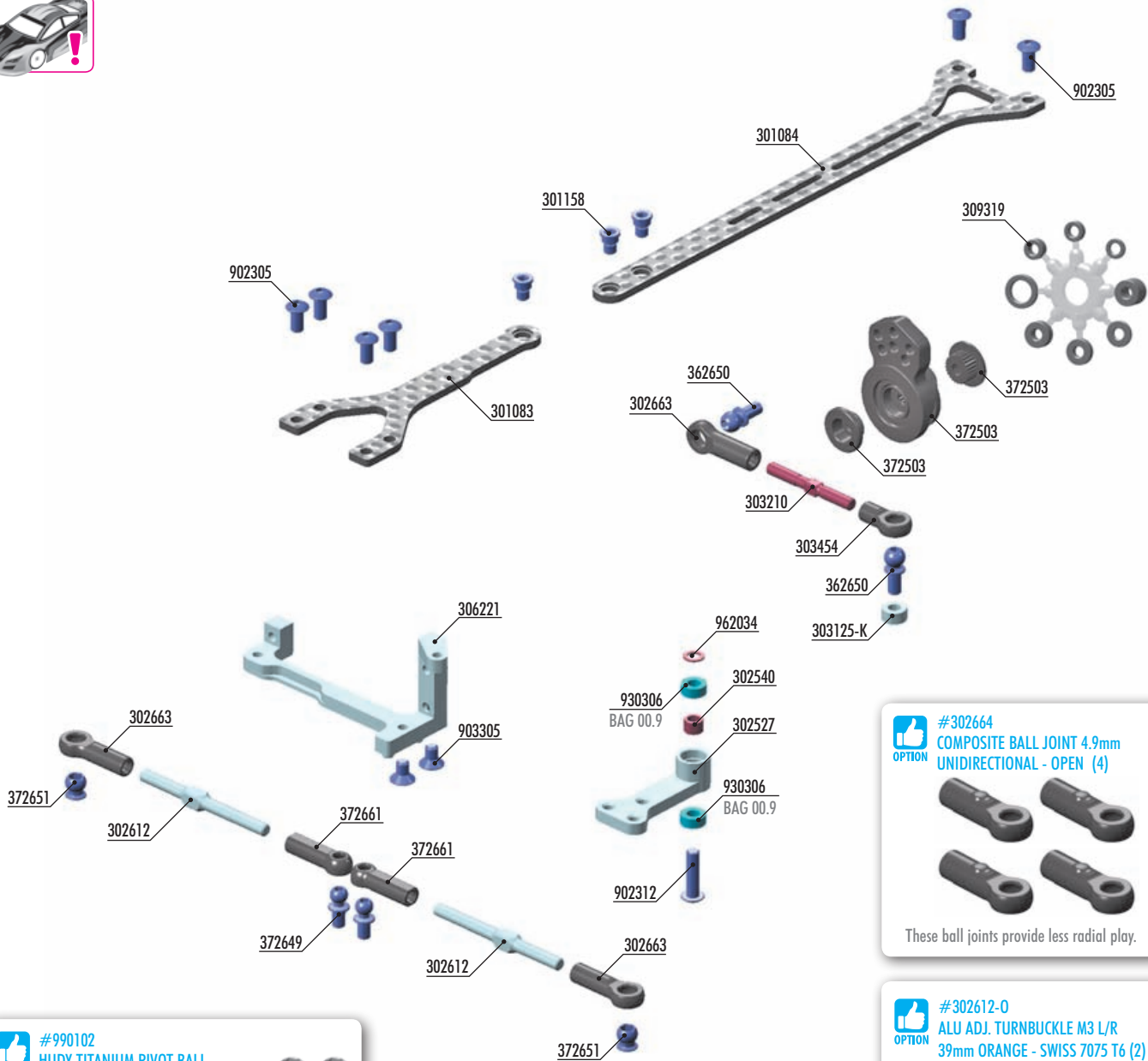

**#302664**  
**OPTION** **COMPOSITE BALL JOINT 4.9mm UNIDIRECTIONAL - OPEN (4)**

These ball joints provide less radial play.

**#302612-0**  
**OPTION** **ALU ADJ. TURNBUCKLE M3 L/R 39mm ORANGE - SWISS 7075 T6 (2)**

**#302610**  
**OPTION** **ADJ. TURNBUCKLE L/R 39mm HUDY SPRING STEEL (2)**

**#990102**  
**OPTION** **HUDY TITANIUM PIVOT BALL D=4.9 / S=3.5 / 3mm HEX (2)**

**#990006**  
**OPTION** **HUDY TITANIUM BALL STUD D=4.9 / L=6 / S=3.5 / 2mm HEX (2)**

**#301085**  
**OPTION** **GRAPHITE UPPER DECK - 2.0mm**

**BAG**  
**04**

- 301083 X4F GRAPHITE UPPER DECK - SPLIT FRONT - 2.0mm
- 301084 X4F GRAPHITE UPPER DECK - SPLIT REAR - 2.0mm
- 301158 TOP DECK HEX SCREW M3x5.5 - HUDY SPRING STEEL™ (2)
- 302527 X4F ALU SERVO SAVER ARM - BLACK - SWISS 7075 T6
- 302540 STEEL SHIM 3x4.5x3.2mm (2)
- 302612 ALU ADJ. TURNBUCKLE M3 L/R 39mm - SWISS 7075 T6 (2)
- 302663 COMPOSITE BALL JOINT 4.9mm - OPEN - V2 (8)
- 303125-K ALU SHIM 3x6x3.0mm - BLACK (10)
- 303210 REAR TURNBUCKLE L/R 26mm - HUDY SPRING STEEL (2)
- 303454 BALL JOINT 4.9mm - OPEN (4)
- 306221 X4F ALU SERVO MOUNT - BLACK - ONE-PIECE - SWISS 7075 T6
- 309319 UNIVERSAL SET OF PLASTIC SHIMS
- 362650 BALL END 4.9mm WITH THREAD 6mm (2)

- 372503 COMPOSITE SERVO SAVER - X-STIFF - SET - V2
- 372649 BALL END 4.2mm WITH 4mm THREAD (2)
- 372651 PIVOT BALL UNIVERSAL 4.9mm (2)
- 372661 COMPOSITE STEERING BALL-JOINT OPEN 4.2mm (4)
- 902305 HEX SCREW SH M3x5 (10)
- 902312 HEX SCREW SH M3x12 (10)
- 903305 HEX SCREW SFH M3x5 (10)
- 930306 BALL-BEARING 3x6x2.5 STEEL-SEALED - OILED (2)
- 962034 STEEL WASHER S 3x4.7x1 (10)

Numbers in parentheses ( ) refer to quantities when purchased separately.



# 4. STEERING

**2x** STEERING LINKS

**!** NOTE ORIENTATION  
Round ball joint on the long side.

LEFT THREAD      RIGHT THREAD

**2x** L=R  
26.1mm

**#302612-0**  
ALU ADJ. TURNBUCKLE M3 L/R  
39mm ORANGE - SWISS 7075 T6 (2)

**#302610**  
ADJ. TURNBUCKLE L/R 39mm  
HUDY SPRING STEEL (2)

**1x** SERVO LINK

Adjust servo link to fit your servo.

LEFT THREAD      RIGHT THREAD

approx. 16mm

- 1x** 902312 SH M3x12
- 1x** 302540 SHIM 3x4.5x3.2
- 1x** 962034 SHIM 3x4.7x1
- 2x** 930306 BB 3x6x2.5

**VIDEO TECH TIP**

STEERING SYSTEM

1mm

3x4.5x3.2mm

3x12mm

ASSEMBLY VIEW

**2x** L=R

Shiny side

**!** NOTE ORIENTATION  
Ball joint open

**!** NOTE ORIENTATION  
(Outside)

Shiny side

ø4.2mm BALL

4mm THREAD

**TIP** Install the pivot balls with Professional Multi Tool (HUDY #183011).

**#990102**  
HUDY TITANIUM PIVOT BALL  
D=4.9 / S=3.5 / 3mm HEX (2)

# 4. STEERING



1x 303125-K SHIM 3x6x3

## SERVO SAVER

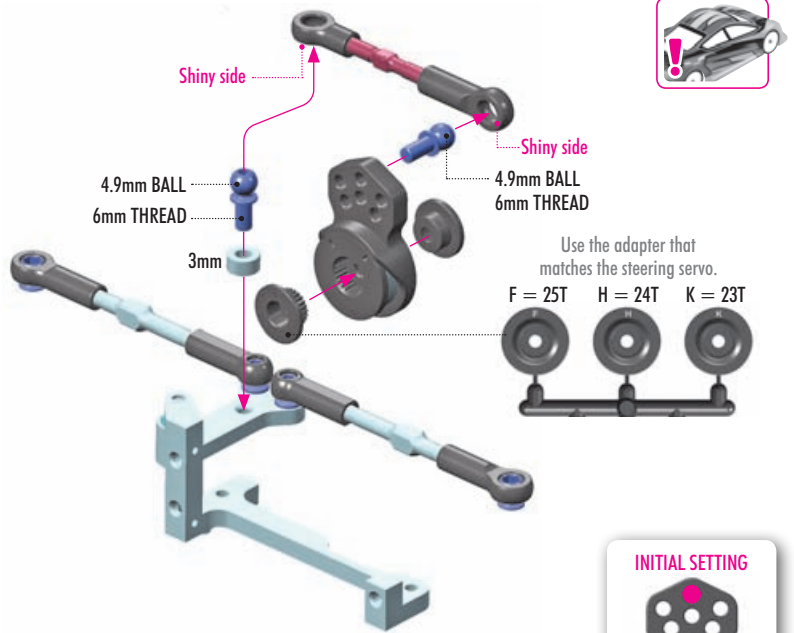
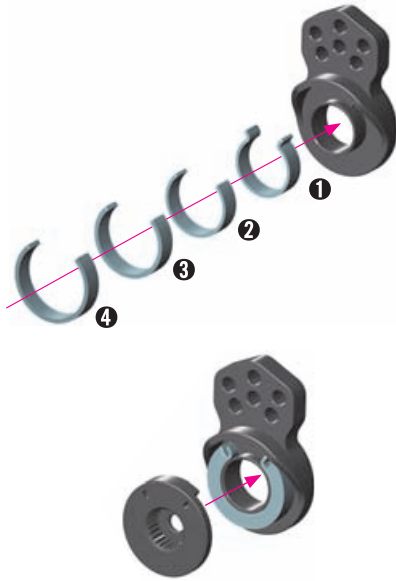

Use the adapter that matches the steering servo.  
F = 25T H = 24T K = 23T

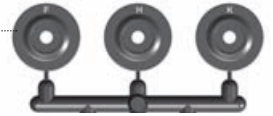

### INITIAL SETTING



**#990006 HUDY TITANIUM BALL STUD**  
D=4.9 / L=6 / S=3.5 / 2mm HEX (2)



### ALU SERVO HORNS - OFFSET

#293491	KO, Sanwa - 23T
#293492	Hitec - 24T
#293493	Savox, Futaba - 25T

### CLAMP ALU SERVO HORNS - OFFSET

#293401	KO, Sanwa - 23T
#293402	Hitec - 24T
#293403	Savox, Futaba - 25T

### CLAMP ALU SERVO HORNS - OFFSET

#293411	KO, Sanwa - 23T
#293412	Hitec - 24T
#293413	Savox, Futaba - 25T



For more in-corner steering and better steering response, aluminum servo horns may be used.



### HUDY ALU SERVO HORNS

#293497	KO, Sanwa - 23T
#293498	Hitec - 24T
#293499	Savox, Futaba - 25T

### HUDY CLAMP ALU SERVO HORNS

#293404	KO, Sanwa - 23T
#293405	Hitec - 24T
#293406	Savox, Futaba - 25T



### HUDY ALU SERVO HORNS

#293501	KO, Sanwa - 23T
#293502	Hitec - 24T
#293503	Savox, Futaba - 25T

### HUDY CLAMP ALU SERVO HORNS

#293407	KO, Sanwa - 23T
#293408	Hitec - 24T
#293409	Savox, Futaba - 25T



**! IMPORTANT!** When an aluminum horn is used, the steering servo saver is NOT used. This increases the risk of breaking the servo in serious crashes.



VIDEO TECH TIP



STEERING SYSTEM



2x 903305 SFH M3x5

**!** Please set the additional shims aside and save for future steps. They are used in Section 7 Page 42 Step 2 to mount the servo.

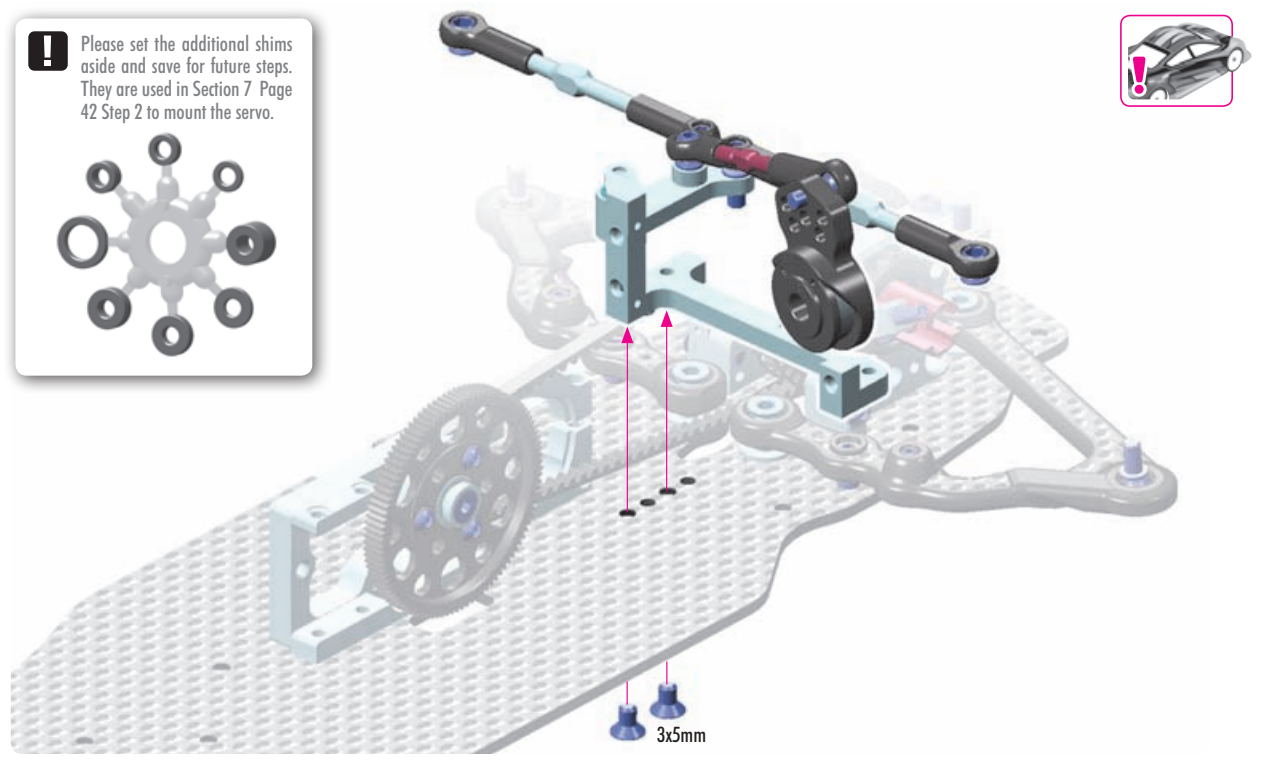





3x 301158  
SCREW 3x5.5



6x 902305  
SH M3x5



#301085  
GRAPHITE UPPER DECK - 2.0mm



Optional one piece top deck increases chassis flex. Suggested for low traction conditions, it may remove some initial steering but generates more overall traction.

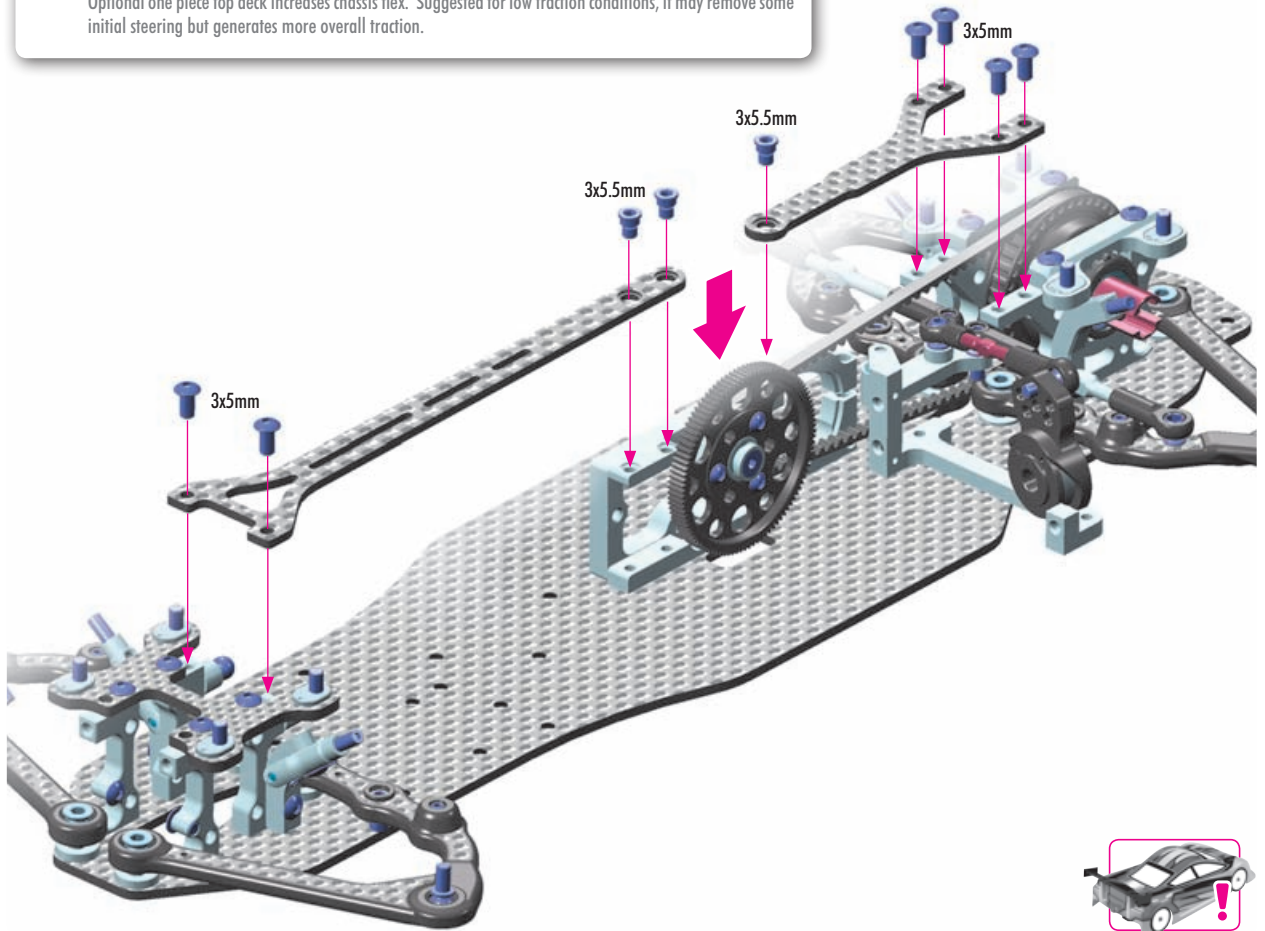

VIDEO TECH TIP



TOP DECK FLEX

## TOP DECK (SPLIT) FLEX SETTINGS

The new feature of the split top deck is the flex setting adjustment. There are two different flex setting alternatives.

**SOFT**

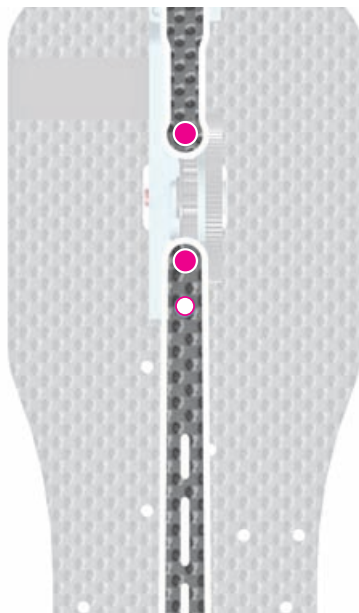

This allows maximum flex and provides maximum steering and rotation. However, the car is less stable on-power.

**STIFF**

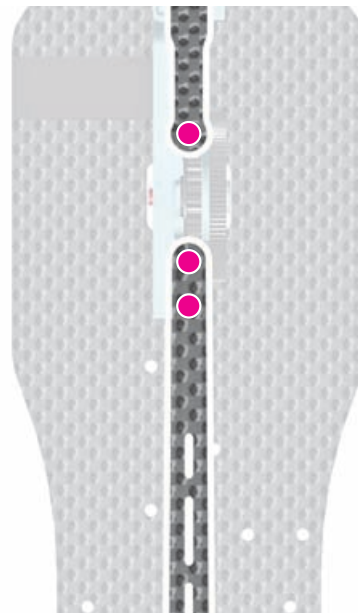

This setting gives reduced flex in the rear which improves stability and on-power traction.

# 5. FRONT & REAR SUSPENSION

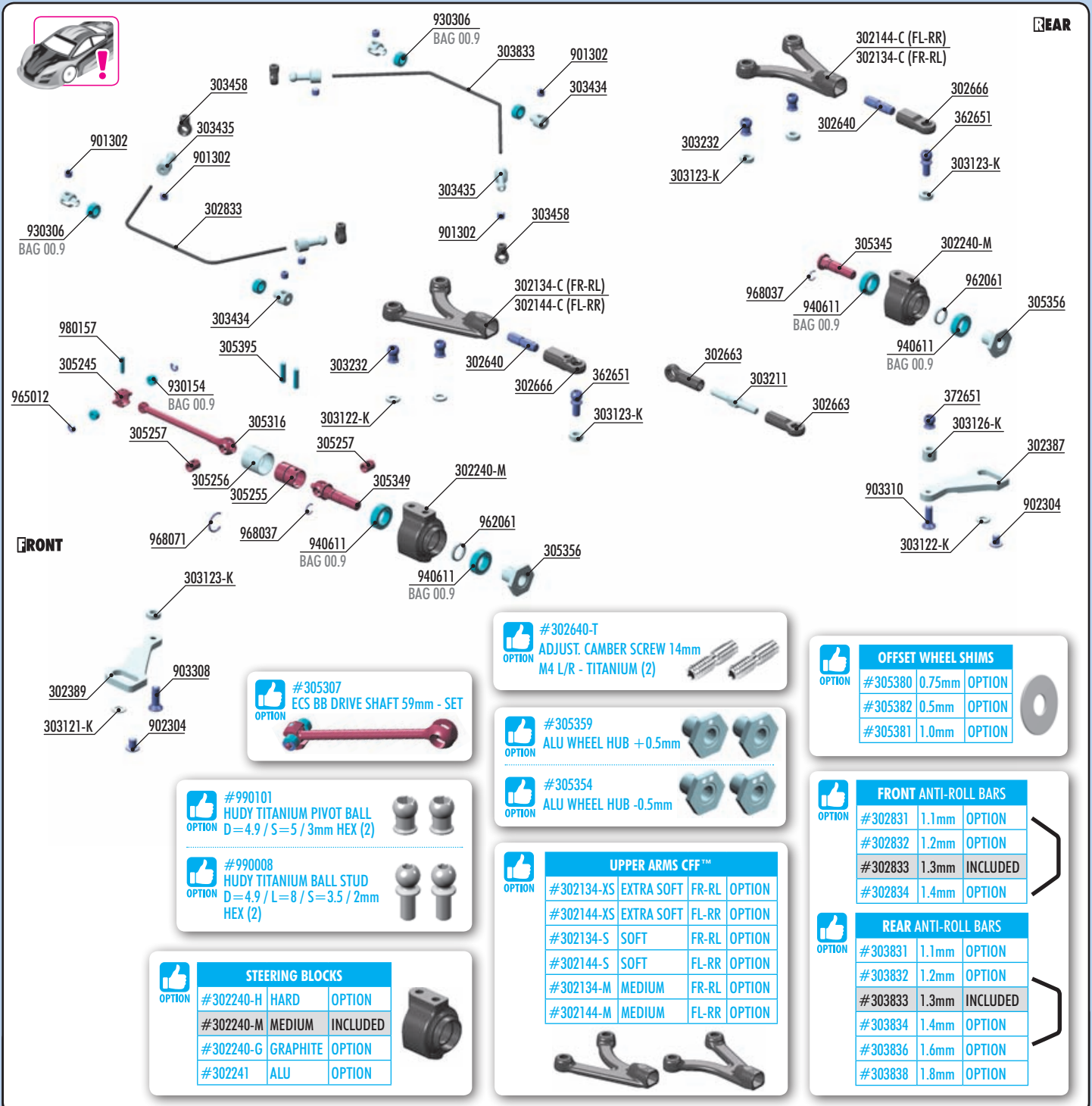

FRONT

REAR

**#305307**  
ECS BB DRIVE SHAFT 59mm - SET

**#302640-T**  
ADJUST. CAMBER SCREW 14mm  
M4 L/R - TITANIUM (2)

OFFSET WHEEL SHIMS			
#305380	0.75mm	OPTION	
#305382	0.5mm	OPTION	
#305381	1.0mm	OPTION	

**#990101**  
HUDY TITANIUM PIVOT BALL  
D=4.9 / S=5 / 3mm HEX (2)

**#990008**  
HUDY TITANIUM BALL STUD  
D=4.9 / L=8 / S=3.5 / 2mm  
HEX (2)

**#305359**  
ALU WHEEL HUB +0.5mm

**#305354**  
ALU WHEEL HUB -0.5mm

FRONT ANTI-ROLL BARS		
#302831	1.1mm	OPTION
#302832	1.2mm	OPTION
#302833	1.3mm	INCLUDED
#302834	1.4mm	OPTION

STEERING BLOCKS		
#302240-H	HARD	OPTION
#302240-M	MEDIUM	INCLUDED
#302240-G	GRAPHITE	OPTION
#302241	ALU	OPTION

UPPER ARMS CFF™			
#302134-XS	EXTRA SOFT	FR-RL	OPTION
#302144-XS	EXTRA SOFT	FL-RR	OPTION
#302134-S	SOFT	FR-RL	OPTION
#302144-S	SOFT	FL-RR	OPTION
#302134-M	MEDIUM	FR-RL	OPTION
#302144-M	MEDIUM	FL-RR	OPTION

REAR ANTI-ROLL BARS		
#303831	1.1mm	OPTION
#303832	1.2mm	OPTION
#303833	1.3mm	INCLUDED
#303834	1.4mm	OPTION
#303836	1.6mm	OPTION
#303838	1.8mm	OPTION



302134-C	X4 COMPOSITE UPPER ARM - INNER SHOCK POSITION - FR/RL	305257	ECS BB SC DRIVE SHAFT COUPLING - HUDY SPRING STEEL™
302144-C	X4 COMPOSITE UPPER ARM - INNER SHOCK POSITION - FL/RR	305306	X4 ECS BB DRIVE SHAFT 58mm - HUDY SPRING STEEL™ - SET
302240-M	X4 COMPOSITE STEERING BLOCK - MEDIUM	305316	X4 ECS BB DRIVE SHAFT 58mm - HUDY SPRING STEEL™ (2)
302387	X4 ALU REAR ARS PLATE - INNER SHOCK POSITION - SWISS 7075 T6 (L+R)	305345	X4F DRIVE AXLE - HUDY SPRING STEEL™
302389	X4F ALU FRONT STEERING PLATE - INNER SHOCK POSITION - 7075 T6 (L+R)	305349	X4 ECS DRIVE AXLE - SPRING CLIP - HUDY SPRING STEEL™
302640	ADJUSTABLE CAMBER SCREW 14mm M4 L/R - HUDY SPRING STEEL™ (2)	305356	X4 ALU WHEEL HUB - SPRING CLIP - SWISS 7075 T6 (2)
302663	COMPOSITE BALL JOINT 4.9mm - OPEN - V2 (8)	305395	ECS BB SC DRIVE SHAFT PIN 2 x 8.4 (2)
302666	COMPOSITE BALL JOINT 4.9mm F+R - OPEN (2+2)	362651	BALL END 4.9mm WITH THREAD 8mm (2)
302833	X4 ANTI-ROLL BAR UAM - UNDER ARM MOUNT - FRONT 1.3mm	372651	PIVOT BALL UNIVERSAL 4.9mm (2)
303121-K	ALU SHIM 3x6x0.5mm - BLACK (10)	901302	HEX SCREW SB M3x2.5 (10)
303122-K	ALU SHIM 3x6x1.0mm - BLACK (10)	902304	HEX SCREW SH M3x4 - STAINLESS (10)
303123-K	ALU SHIM 3x6x2.0mm - BLACK (10)	903308	HEX SCREW SFH M3x8 (10)
303126-K	ALU SHIM 3x6x5.0mm - BLACK (10)	903310	HEX SCREW SFH M3x10 (10)
303211	ALU ADJUSTABLE TURNBUCKLE L/R 30mm - SWISS 7075 T6 (2)	930154	BALL-BEARING 1.5x4x2 STEEL-SEALED - OIL (4)
303232	X4 UPPER ARM BALL UNIVERSAL 4.9mm - HUDY SPRING STEEL™ (2)	930306	BALL-BEARING 3x6x2.5 STEEL-SEALED - OIL (2)
303434	ALU ANTI-ROLL BAR BUSHING ø2.0mm - 6mm (2)	940611	BALL-BEARING 6x10x3 RUBBER SEALED - OIL (2)
303435	ALU ANTI-ROLL BAR BALL END 3.9mm - SWISS 7075 T6 (2)	962061	WASHER S 6x7.5x1.0 (10)
303458	COMPOSITE ANTI-ROLL BAR BALL JOINT 3.9mm (4)	965012	E-CLIP 1.2 (10)
303833	X4 ANTI-ROLL BAR UAM - UNDER ARM MOUNT - REAR 1.3mm	968037	C-CLIP 3.7 (10)
305245	ECS BB DRIVE SHAFT ADAPTER - HUDY SPRING STEEL™ (2)	968071	C-CLIP 7.1 (10)
305255	ECS BB SC DRIVE SHAFT CASE - HUDY SPRING STEEL™	980157	PIN 1.5x7.3 (10)
305256	ECS BB SC ALU DRIVE SHAFT SLEEVE - SWISS 7075 T6		

Numbers in parentheses ( ) refer to quantities when purchased separately.



# 5. FRONT & REAR SUSPENSION

4x 305395  
P 2x8.4

2x 968037  
C 3.7

2x 968071  
C 7.1

## 2x FRONT TRANSMISSION - ECS DRIVE SHAFT

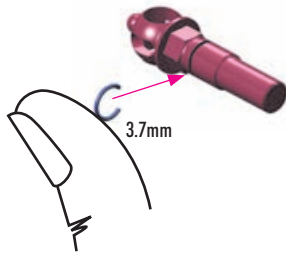

Insert the clip into the groove on the axle. The clip should fit smoothly without extra force and should NOT require pliers. Make sure the clip will rotate after installation.



2x

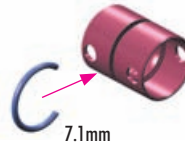

2x

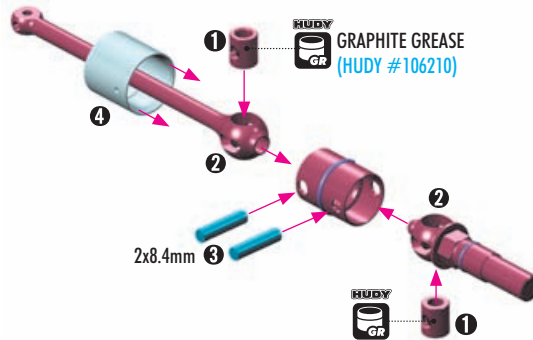

2x

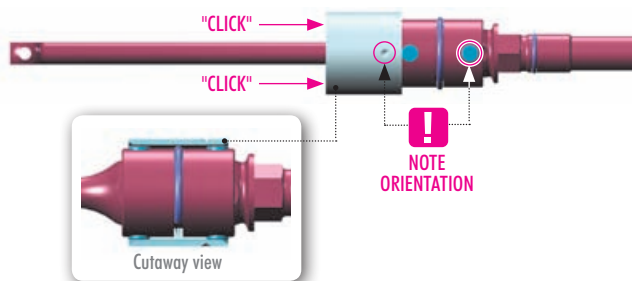

VIDEO TECH TIP



DRIVE SHAFTS

4x 930154  
BB 1.5x4x2

4x 965012  
E 1.2

2x

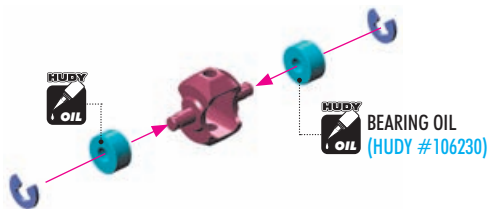

2x

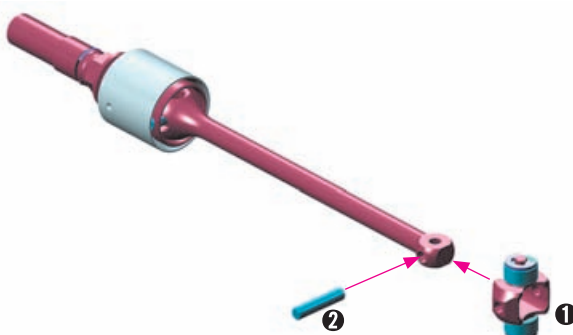

## DISASSEMBLY OF ECS DRIVE SHAFT

To disassemble the alu drive shaft sleeve from the drive shaft, hold the sleeve firmly with a HUDY Multi-Tool, and lightly push the drive shaft down against a flat surface.





# 5. FRONT & REAR SUSPENSION

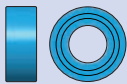

4x 940611  
BB 6x10x3



2x 962061  
S 6x7.5x1



2x 968037  
C 3.7



VIDEO TECH TIP



FRONT & REAR  
UPRIGHTS

## 2x REAR TRANSMISSION

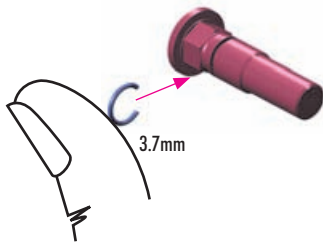

Insert the clip into the groove on the axle. The clip should fit smoothly without extra force and should NOT require pliers. Make sure the clip will rotate after installation.



### STEERING BLOCKS

OPTION	#	MATERIAL	INCLUDED
	#302240-M	MEDIUM	INCLUDED
	#302240-H	HARD	OPTION
	#302240-G	GRAPHITE	OPTION
	#302241	ALU	OPTION



**MEDIUM** hubs generate the maximum amount of side traction, which is the best starting point for most conditions.

**HARD** hubs' additional stiffness is recommended for low to medium traction conditions for balanced handling with good traction and cornering speed.

**GRAPHITE** hubs are recommended for high to very high traction conditions to help improve rotation and cornering speed.

**ALU** hubs are recommended for high traction surfaces to improve rotation and free up the car, but they will decrease traction. ALU hubs also improve durability in serious crashes.



### OFFSET WHEEL SHIMS

OPTION	#	THICKNESS	INCLUDED
	#305380	0.75mm	OPTION
	#305382	0.5mm	OPTION
	#305381	1.0mm	OPTION



To adjust the width of the car, optional wheel shims can be quickly added or removed.



#305359  
**ALU WHEEL HUB +0.5mm**



The wider wheel hubs free up the car and improve cornering speed in high traction conditions.



#305354  
**ALU WHEEL HUB -0.5mm**



For very low traction conditions, the narrower wheel hubs can generate more traction and steering but will make the car nervous and decrease cornering speed.

Left UPRIGHT = Right UPRIGHT

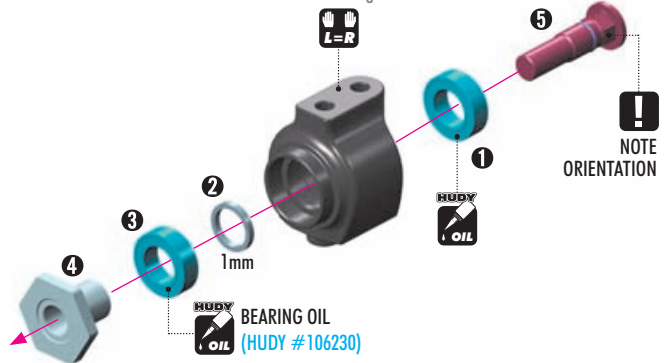

"CLICK"

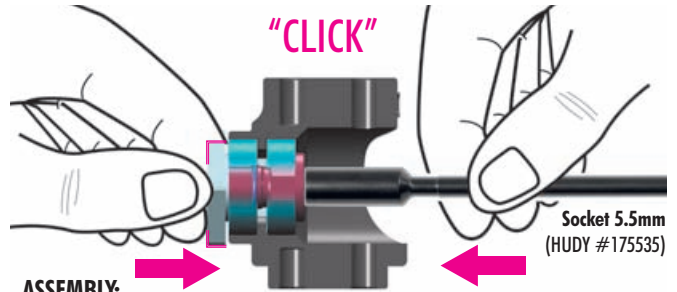

### ASSEMBLY:

When installing the wheel hub on the drive axle, make sure the inside groove in the hub seats over the clip on the axle.

To confirm proper installation there should be a 'click' noise when the clip engages the inner groove in the wheel hub. There should be slight axial play once fully seated.

### DISSASSEMBLY:

To remove the wheel hub from the axle, push the end of the axle back through the wheel hub to separate the wheel hub from the inner clip.

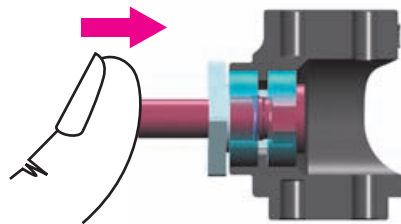

CUTAWAY VIEW

## 2x REAR TRANSMISSION

3x10mm



DO NOT OVERTIGHTEN

The thread in the rear ARS plate is very short; therefore, make sure to tighten the screw gently.

NOTE ORIENTATION



ASSEMBLY VIEW

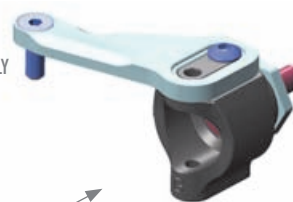

BOTTOM VIEW



2x 902304  
SH M3x4

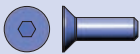

2x 903310  
SFH M3x10

# 5. FRONT & REAR SUSPENSION

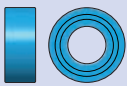

4x 940611  
BB 6x10x3



2x 962061  
S 6x7.5x1

## 2x FRONT TRANSMISSION



### OFFSET WHEEL SHIMS

#305380	0.75mm	OPTION
#305382	0.5mm	OPTION
#305381	1.0mm	OPTION



To adjust the width of the car, optional wheel shims can be quickly added or removed.



### STEERING BLOCKS

#302240-M	MEDIUM	INCLUDED
#302240-H	HARD	OPTION
#302240-G	GRAPHITE	OPTION
#302241	ALU	OPTION



**MEDIUM** hubs generate the maximum amount of side traction, which is the best starting point for most conditions.

**HARD** hubs' additional stiffness is recommended for low to medium traction conditions for balanced handling with good traction and cornering speed.

**GRAPHITE** hubs are recommended for high to very high traction conditions to help improve rotation and cornering speed.

**ALU** hubs are recommended for high traction surfaces to improve rotation and free up the car, but they will decrease traction. Alu hubs also improve durability in serious crashes.



#305359  
ALU WHEEL HUB +0.5mm



The wider wheel hubs free up the car and improve cornering speed in high traction conditions.



#305354  
ALU WHEEL HUB -0.5mm



For very low traction conditions, the narrower wheel hubs can generate more traction and steering but will make the car nervous and decrease cornering speed.

Use Steel 58mm BB ECS  
Drive Shafts in FRONT.

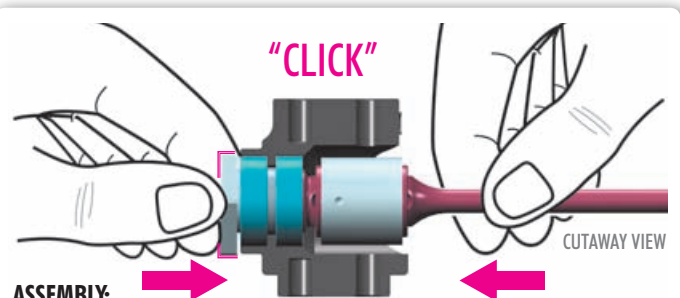
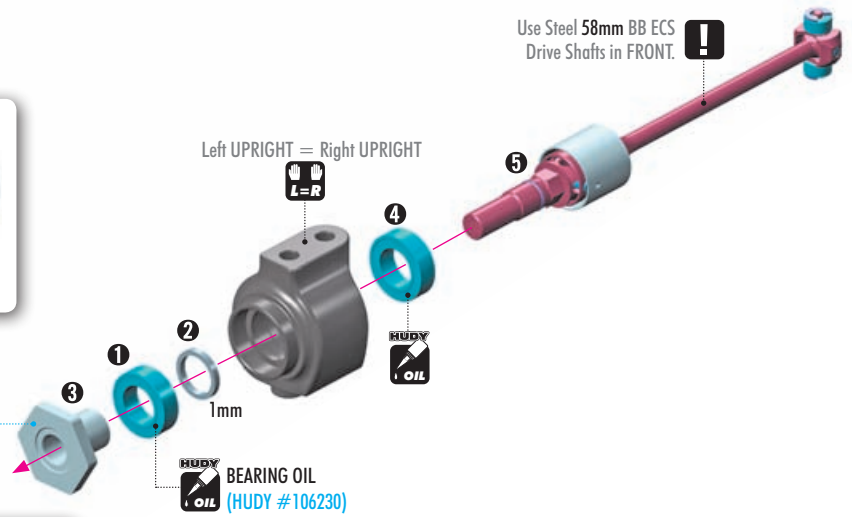

### ASSEMBLY:

When installing the wheel hub on the drive axle, make sure the inside groove in the hub seats over the clip on the axle.

To confirm proper installation there should be a 'click' noise when the clip engages the inner groove in the wheel hub. There should be slight axial play once fully seated.

### DISSASSEMBLY:

To remove the wheel hub from the axle, push the end of the axle back through the wheel hub to separate the wheel hub from the inner clip.

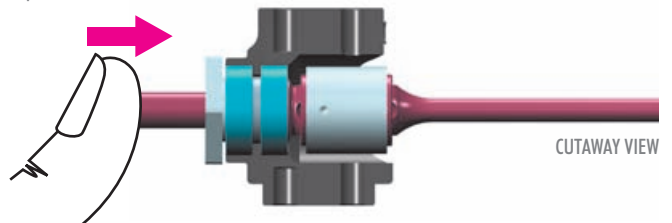

## 2x FRONT TRANSMISSION



2x 902304  
SH M3x4

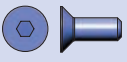

2x 903308  
SFH M3x8

### DO NOT OVERTIGHTEN

The threads in the front steering plate are very short; take caution to tighten the screw gently.

3x8mm

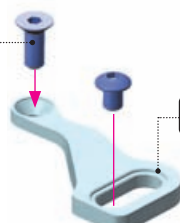

NOTE  
ORIENTATION

ASSEMBLY  
VIEW



BOTTOM  
VIEW

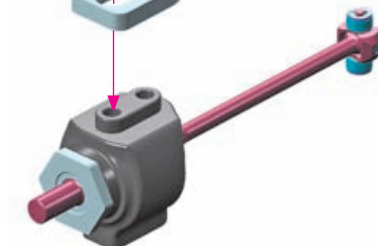

# 5. FRONT & REAR SUSPENSION

**2x REAR**

Push inside  
1

Apply Graphite Grease

2 Tighten  
2.0 mm

29.5mm

#302640-T  
OPTION ADJUST. CAMBER SCREW 14mm  
M4 L/R - TITANIUM (2)

**2x FRONT**

Push inside  
1

Apply Graphite Grease

2 Tighten  
2.0 mm

31mm

VIDEO TECH TIP

CAMBER & UPPER ARMS

**2x REAR**

2.0 mm

24.2mm

**! BOTTOM NOTE ORIENTATION**

Shiny side

Ball joint should be aligned in the arm with the shiny side facing down.

**FRONT**

**RIGHT** **FR-RL** **BOTTOM VIEW** **FR-RL** **LEFT**

**REAR**

Check arm orientation so that each arm is in the correct location with the markings facing down when installed.

**2x FRONT**

2.0 mm

26.3mm

**! BOTTOM NOTE ORIENTATION**

Shiny side - Cut out

Ball joint should be aligned in the arm with the machined clearance facing down.

**FRONT**

**RIGHT** **FR-RL** **BOTTOM VIEW** **FR-RL** **LEFT**

**REAR**

Check arm orientation so that each arm is in the correct location with the markings facing down when installed.

303122-K  
SHIM 3x6x1

VIDEO TECH TIP

ROLL-CENTER

**2x REAR SUSPENSION**

ASSEMBLY VIEW

1mm

**(INITIAL SETTING)**

Raising the rear axle height will improve rotation and off-power steering. Recommended for medium to high traction asphalt surfaces. Minimum shim thickness is 0.5mm; DO NOT use thinner.



# 5. FRONT & REAR SUSPENSION

2x 303121-K SHIM 3x6x0.5

## 2x FRONT SUSPENSION

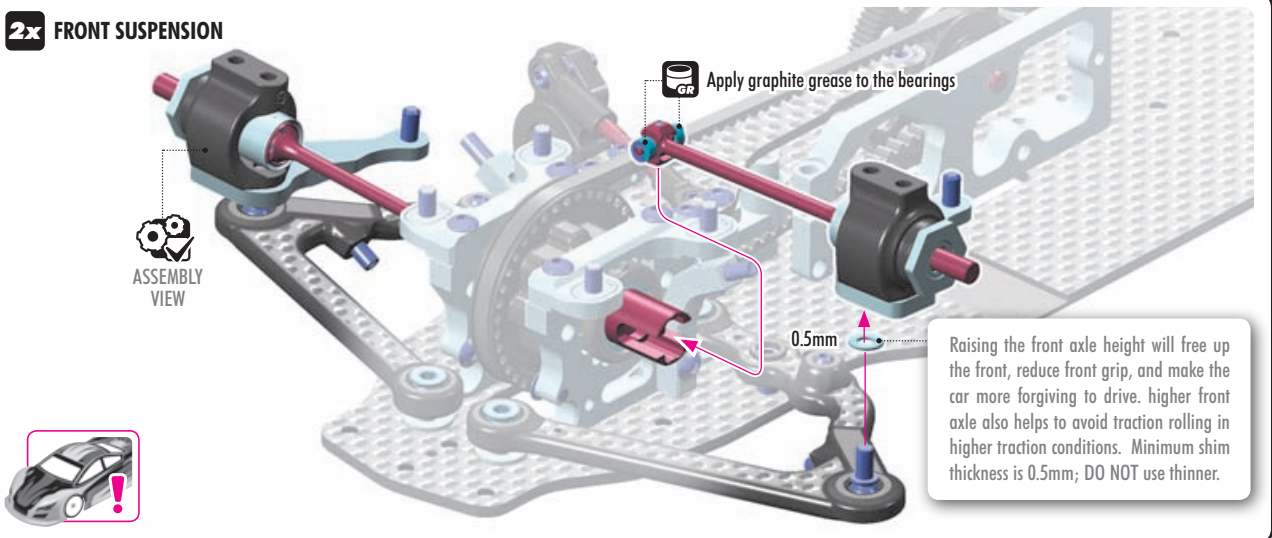

Raising the front axle height will free up the front, reduce front grip, and make the car more forgiving to drive. Higher front axle also helps to avoid traction rolling in higher traction conditions. Minimum shim thickness is 0.5mm; DO NOT use thinner.



6x 303123-K SHIM 3x6x2

## 2x REAR SUSPENSION

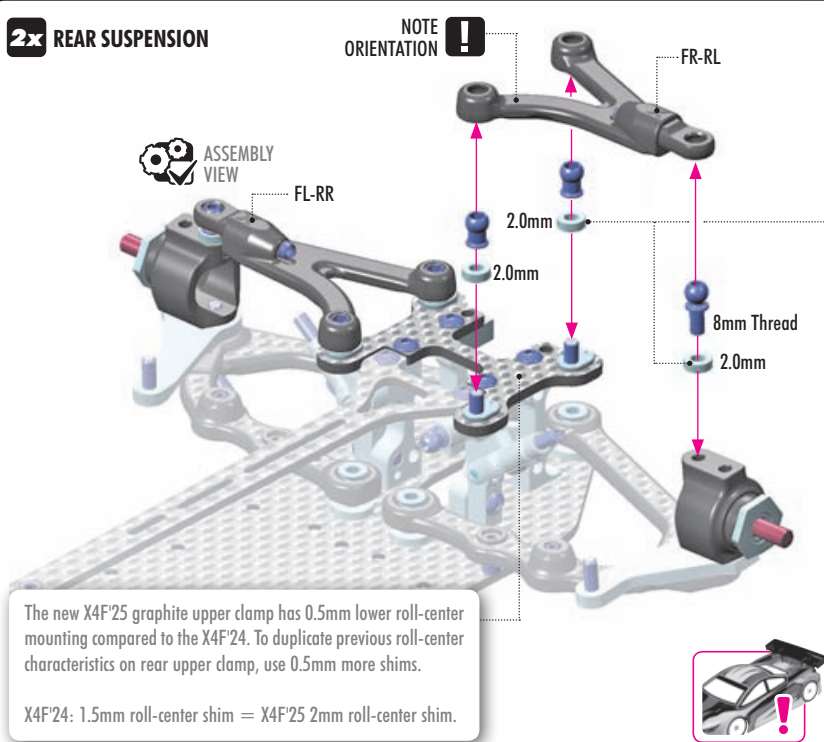

Rear upper arm location affects the rear roll-center and camber gain. Raising the arm with thicker shims on the graphite upper clamp will lower the rear roll-center and decrease camber gain. Reducing the shim height on the upper clamps has the same effect as increasing the shim height on the outside.

Thicker shim on graphite upper clamp provides more rotation and off-power steering but decreases rear traction.

- #990101 HUDY TITANIUM PIVOT BALL OPTION D=4.9 / S=5 / 3mm HEX (2)
- #990008 HUDY TITANIUM BALL STUD OPTION D=4.9 / L=8 / S=3.5 / 2mm HEX (2)

VIDEO TECH TIP

ROLL-CENTER

The new X4F'25 graphite upper clamp has 0.5mm lower roll-center mounting compared to the X4F'24. To duplicate previous roll-center characteristics on rear upper clamp, use 0.5mm more shims.

X4F'24: 1.5mm roll-center shim = X4F'25 2mm roll-center shim.

4x 303122-K SHIM 3x6x1

2x 303123-K SHIM 3x6x2

## 2x FRONT SUSPENSION

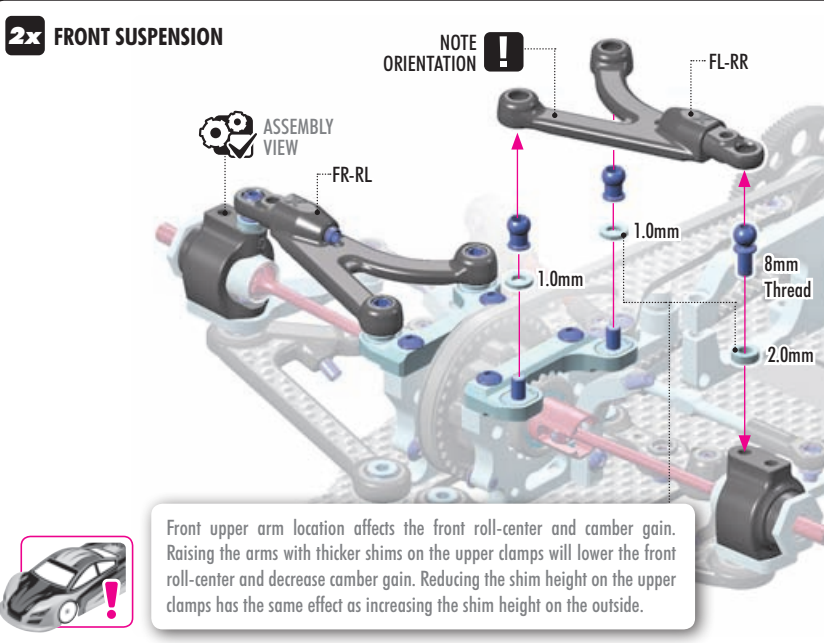

Composite upper arms are included in the kit for maximum traction and side bite. Using harder upper arms will increase steering response and rotation while reducing traction and side bite.

**EXTRA SOFT** upper arms are recommended for low traction conditions

**SOFT** upper arms are recommended for medium traction conditions

**MEDIUM** upper arms are recommended for high traction conditions.

- #990101 HUDY TITANIUM PIVOT BALL OPTION D=4.9 / S=5 / 3mm HEX (2)
- #990008 HUDY TITANIUM BALL STUD OPTION D=4.9 / L=8 / S=3.5 / 2mm HEX (2)



Front upper arm location affects the front roll-center and camber gain. Raising the arms with thicker shims on the upper clamps will lower the front roll-center and decrease camber gain. Reducing the shim height on the upper clamps has the same effect as increasing the shim height on the outside.

# 5. FRONT & REAR SUSPENSION

## 2x REAR LINKS

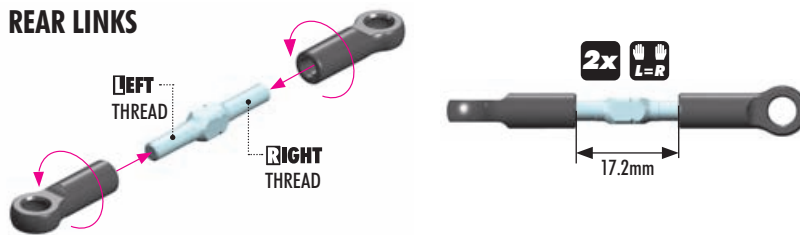

**#303211-O ALU TURNBUCKLE L/R**  
**30mm ORANGE - SWISS 7075 T6 (2)**  
 OPTION

**2x 303126-K SHIM 3x6x5**

**VIDEO TECH TIP**

REAR TOE-GAIN

## 2x REAR TRANSMISSION

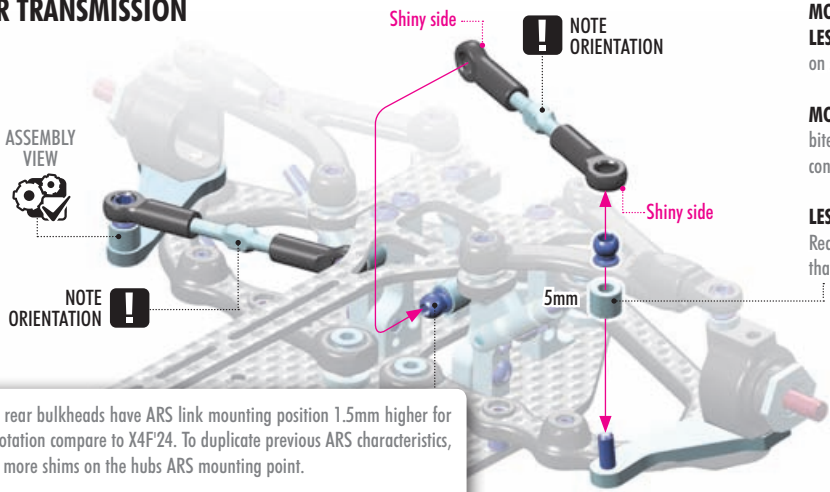

The X4F'25 rear bulkheads have ARS link mounting position 1.5mm higher for improved rotation compare to X4F'24. To duplicate previous ARS characteristics, use 1.5mm more shims on the hubs ARS mounting point.  
 X4F'25: 5mm Hub Shim = X4F'24: 3.5mm Hub Shim.

**MORE SHIMS** gives more toe-gain on compression.  
**LESS SHIMS** gives less toe-gain (or even toe loss), on suspension compression.

**MORE TOE-GAIN** improves rear grip and side bite. Mainly recommended for low- to medium-grip conditions.

**LESS TOE-GAIN** reduces rear grip and side bite. Recommended for higher- grip conditions or tracks that require more steering.



**2x 303123-K SHIM 3x6x2**

**VIDEO TECH TIP**

STEERING SYSTEM

## 2x FRONT TRANSMISSION

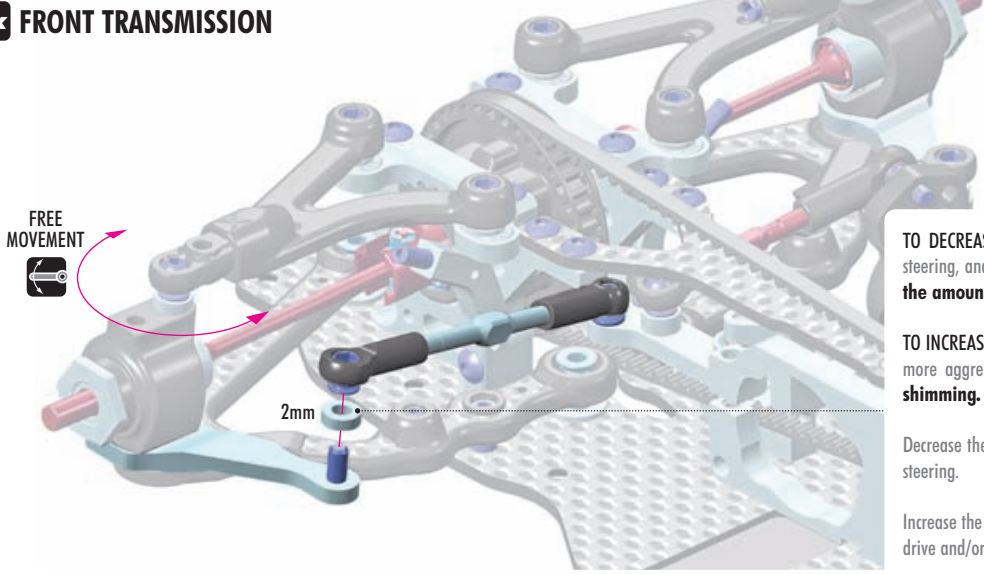

**TO DECREASE** bump steer, smoothen out the steering, and reduce traction rolling: **increase the amount of shimming.**

**TO INCREASE** bump steer, to make the steering more aggressive, **decrease the amount of shimming.**

Decrease the amount of shimming to get more steering.

Increase the shimming if the car is difficult to drive and/or it is traction rolling.



**2x 930306 BB 3x6x2.5**

**VIDEO TECH TIP**

ANTI-ROLL BARS

## 2x FRONT & REAR ANTI-ROLL BARS



FRONT ANTI-ROLL BARS			
#302831	1.1mm	OPTION	}
#302832	1.2mm	OPTION	
#302833	1.3mm	INCLUDED	
#302834	1.4mm	OPTION	
REAR ANTI-ROLL BARS			
#303831	1.1mm	OPTION	}
#303832	1.2mm	OPTION	
#303833	1.3mm	INCLUDED	
#303834	1.4mm	OPTION	
#303836	1.6mm	OPTION	
#303838	1.8mm	OPTION	



# 5. FRONT & REAR SUSPENSION

**4x**

**TIP** Install the pivot balls with **Professional Multi Tool (HUDY #183011)**.

**REAR ANTI-ROLL BAR**

**IMPORTANT:** DO NOT overtighten.

**ASSEMBLY VIEW**

**BOTTOM VIEW**

**2x** 901302 SB M3x2.5

**REAR ANTI-ROLL BAR**

**DETAIL** **CENTER** **TOP VIEW**

Set the bar into the **CENTER**, remove the play in the bushings, and tighten the set-screws fully.

**2x** 901302 SB M3x2.5

**REAR ANTI-ROLL BARS**

#303831	1.1mm	OPTION
#303832	1.2mm	OPTION
#303833	1.3mm	INCLUDED
#303834	1.4mm	OPTION
#303836	1.6mm	OPTION
#303838	1.8mm	OPTION

**SOFTER** rear anti-roll bar:  
Generates more side traction. Mainly recommended for low-grip asphalt tracks.

**STIFFER** rear anti-roll bar:  
Helps the car stay flatter and reduces traction rolling on high-grip surfaces.

**BOTTOM VIEW**

1.5 mm

**VIDEO TECH TIP**

**ANTI-ROLL BARS**

When the bars are set, verify that both sides move at the same time. If they do, the bars are set up correctly. If NOT, make sure that both downstops are the same and that the bar wire is flat.

If both sides still **DO NOT** move at the same time, adjust the length of the bar holders.



# 5. FRONT & REAR SUSPENSION

**FRONT ANTI-ROLL BAR**

ASSEMBLY VIEW

IMPORTANT: Do not overtighten.

BOTTOM VIEW

2x 901302 SB M3x2.5

**FRONT ANTI-ROLL BAR**

DETAIL CENTER TOP VIEW

3x2.5mm

1 2 3

Set the bar into the **CENTER**, remove the play in the bushings, and tighten the set-screws fully.

FRONT ANTI-ROLL BARS			
OPTION	#302831	1.1mm	OPTION
	#302832	1.2mm	OPTION
	#302833	1.3mm	INCLUDED
	#302834	1.4mm	OPTION

2x 901302 SB M3x2.5

FRONT

BOTTOM VIEW

3x2.5mm

1 2

1.5mm

When the bars are set, verify that both sides move at the same time. If they do, the bars are set up correctly. If NOT, make sure that both downstops are the same and that the bar wire is flat.

If both sides still DO NOT move at the same time, adjust the length of the bar holders.

VIDEO TECH TIP

ANTI-ROLL BARS

# 6. SHOCK ABSORBERS

4x

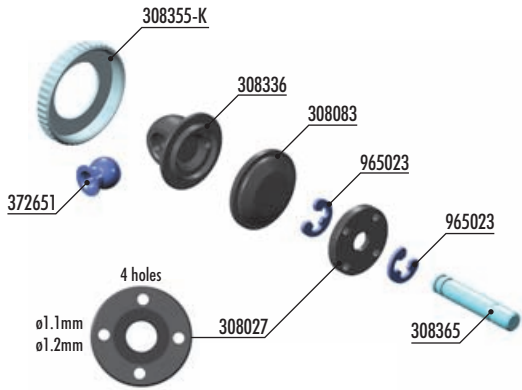

**#104002**  
**HUDY AIR VAC – VACUUM PUMP - ON-ROAD**  
 OPTION

**XRAY SPRINGS**

Part #	Spring Rate (C)	Availability
#308164	C = 2.4-2.7	OPTION
#308165	C = 2.5-2.8	INCLUDED
#308166	C = 2.6-2.9	OPTION
#308175	C = 2.5	OPTION
#308176	C = 2.6	INCLUDED
#308177	C = 2.7	OPTION
#308178	C = 2.8	OPTION
#308179	C = 2.9	OPTION

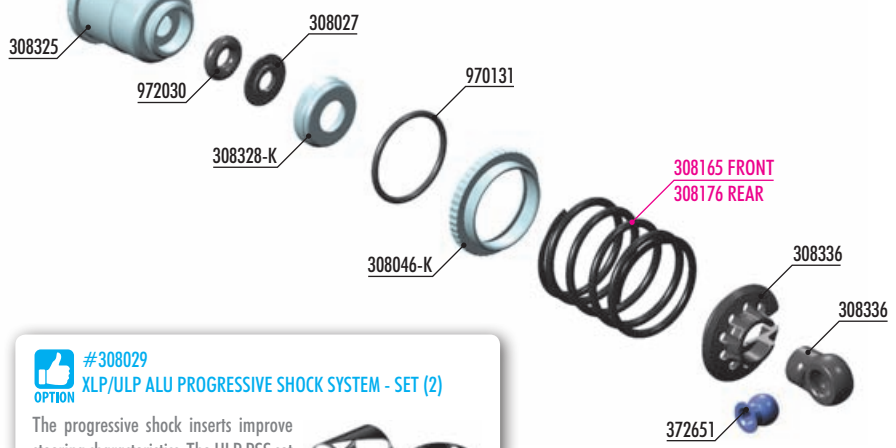

**#308029**  
**XLP/ULP ALU PROGRESSIVE SHOCK SYSTEM - SET (2)**  
 OPTION

The progressive shock inserts improve steering characteristics. The ULP PSS set fits the stock XLP shock bodies included in the kit. Must be used with: #308026 - XLP Progressive Pistons.

**#308033-K**  
**ALU XLP SHOCK SPRING RETAINING COLLAR - BLACK (4)**  
 OPTION

**#308026**  
**XLP COMPOSITE 2-HOLE ø0.8mm PROGRESSIVE PISTON (4)**  
 OPTION

**VIDEO TECH TIP** SHOCKS & SPRINGS

**BAG**  
**06**

- |          |   |        |   |
|----------|---|--------|---|
| 308027   | XLP COMPOSITE 4-HOLE 1.1-1.2mm PISTON (2+2) | 308365 | XLP HARDENED SHOCK SHAFT (2)                        |
| 308046-K | XLP ALU SHOCK ADJUSTABLE NUT - BLACK (2)    | 372651 | PIVOT BALL UNIVERSAL 4.9mm - HUDY SPRING STEEL™ (2) |
| 308083   | XLP SHOCK ABSORBER MEMBRANE (4)             | 965023 | E-CLIP 2.3 (10)                                     |
| 308092   | <b>SHOCK FOAM INSERTS (4) (OPTION)</b>      | 970131 | O-RING 13 x 1.0 (10)                                |
| 308309-K | XLP ALU SHOCK ABSORBER-SET - BLACK (2)      | 972030 | SILICONE O-RING 3 x 2 (10)                          |
| 308325   | XLP ALU SHOCK BODY (2)                      | 308165 | XLP SPRING-SET PROGRESSIVE C=2.5-2.8 (2)            |
| 308328-K | XLP ALU CAP FOR SHOCK BODY - BLACK (2)      | 308176 | XLP SPRING-SET C=2.6 (2)                            |
| 308336   | XLP COMPOSITE SHOCK PARTS WITH 2 HOLES      |        |   |
| 308355-K | XLP ALU SHOCK CAP-NUT - BLACK (2)           |        |   |

Numbers in parentheses ( ) refer to quantities when purchased separately.

8x 965023  
 £ 2.3

**4x**

**NOTE ORIENTATION**

1. Insert E-clip (965023) into the shock shaft (308365).

2. Insert the 4-hole piston (308027) into the shock shaft. Initial setting: 4 holes (INITIAL SETTING).

3. Insert the 2-hole piston (308026) into the shock shaft. Initial setting: ø1.1mm (INITIAL SETTING) and ø1.2mm.

**#308026**  
**XLP COMPOSITE 2-HOLE ø0.8mm PROGRESSIVE PISTON (4)**  
 OPTION

These pistons must be used with optional: #308029 XLP/ULP PROGRESSIVE SHOCK INSERTS

# 6. SHOCK ABSORBERS

**8x** 972030  
0 3x2

**4x**

SHOCK OIL

SHOCK OIL

NOTE ORIENTATION

**4x** 970131  
0 13x1.0

**4x**

SHOCK OIL

SHOCK OIL

1

2

CUTAWAY VIEW

Be careful NOT to cross-thread the collar on the shock body.

**4x**

INCORRECT ✗

CORRECT ✓

8-8.5mm INITIAL SETTING

**HINT:** Pre-thread the ball joint using an M3 screw.  
**WARNING!** Be careful NOT to pre-thread too far, since the ball joint may split or the plastic threads may strip out.

VIDEO TECH TIP

HUDY AIR-VAC SHOCK BUILD

**OIL 350cSt**

**SHOCK FILLING**

- 1 Fully extend the piston rod so the piston is at the bottom of the shock body.
- 2 Hold the shock upright and slightly overfill the shock body with shock oil.
- 3 Let the oil settle and allow air bubbles to rise to the top. Slowly move the piston up and down to allow oil into all cavities within the shock body.
- 4 Extend the piston rod most of the way out of the shock body. Let the shock rest for 5 minutes to allow the air bubbles to escape.
- 5 Add shock oil as necessary.

**TIP** #104002 HUDY AIR VAC – VACUUM PUMP

OPTION	SHOCK OILS (50ml)	OPTION	OPTION
# 106325	250cSt	OPTION	#106352 525cSt OPTION
# 106330	300cSt	OPTION	#106355 550cSt OPTION
# 106335	350cSt	INCLUDED	#106357 575cSt OPTION
# 106337	375cSt	OPTION	#106360 600cSt OPTION
# 106340	400cSt	OPTION	#106362 625cSt OPTION
# 106342	425cSt	OPTION	#106365 650cSt OPTION
# 106344	445cSt	OPTION	#106367 675cSt OPTION
# 106345	450cSt	OPTION	#106370 700cSt OPTION
# 106347	475cSt	OPTION	#106375 750cSt OPTION
# 106350	500cSt	OPTION	#106380 800cSt OPTION

To make sure that all the air is removed from the shock oil, we recommend using the HUDY Air Vac.

**4x**



# 6. SHOCK ABSORBERS

4x

For most conditions, 0-25% rebound is recommended. This is the most forgiving and best to absorb bumps. Cornering speed is generally the best with this setting.

0~25% Rebound  
(INITIAL SETTING)



**IMPORTANT**  
When building the shocks with brand new membranes, some rebound may occur. After a few runs, or letting the shock settle for 24 hours, the membrane will break-in and zero rebound will be possible.



## 1 REBOUND ADJUSTMENT

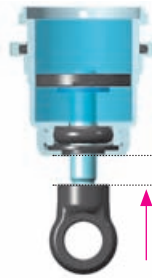

50% Rebound



100% Rebound

For certain low grip conditions, adding additional rebound may improve initial reaction and side bite. Direction change will be faster and may feel like the car is creating more traction. Note that higher rebound settings will make the car less stable over bumps and may increase the tendency to traction roll.

4x

### 2 Insert shock membrane.



### 3 Gently push shock membrane to remove excess oil.



But DO NOT push the membrane too hard otherwise it can fall inside the shock body.

### 4 Tighten shock cap.

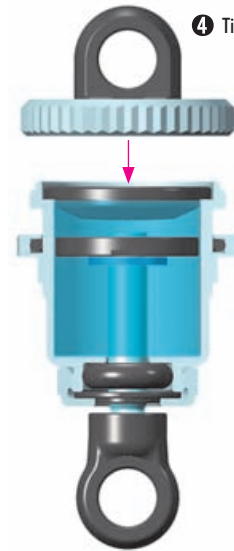

4x

## SHOCK LENGTH ADJUSTMENT:



It is VERY IMPORTANT that all shocks are equal length.

Fully extend the shock absorber and measure the end-to-end length; we recommend using digital calipers to give an accurate measurement. If a shock absorber is shorter or longer than others, adjust the shock length by tightening or loosening the ball joint on the shock rod.

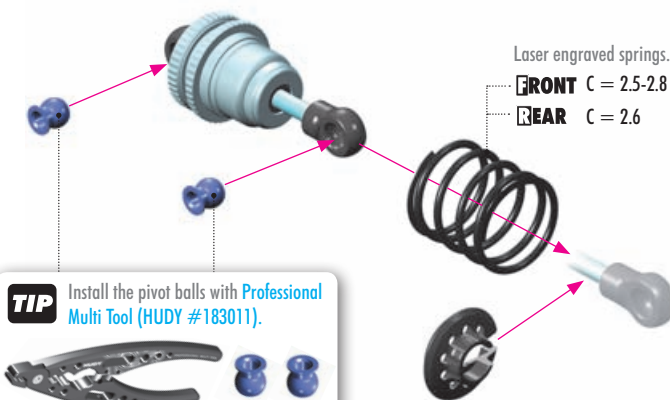

Laser engraved springs.

**FRONT** C = 2.5-2.8

**REAR** C = 2.6

**TIP** Install the pivot balls with Professional Multi Tool (HUDY #183011).



#308033-K

ALU XLP SHOCK SPRING RETAINING COLLAR - BLACK (4)



ASSEMBLY VIEW



VIDEO TECH TIP



SHOCKS & SPRINGS

# 7. FRONT & REAR ASSEMBLY

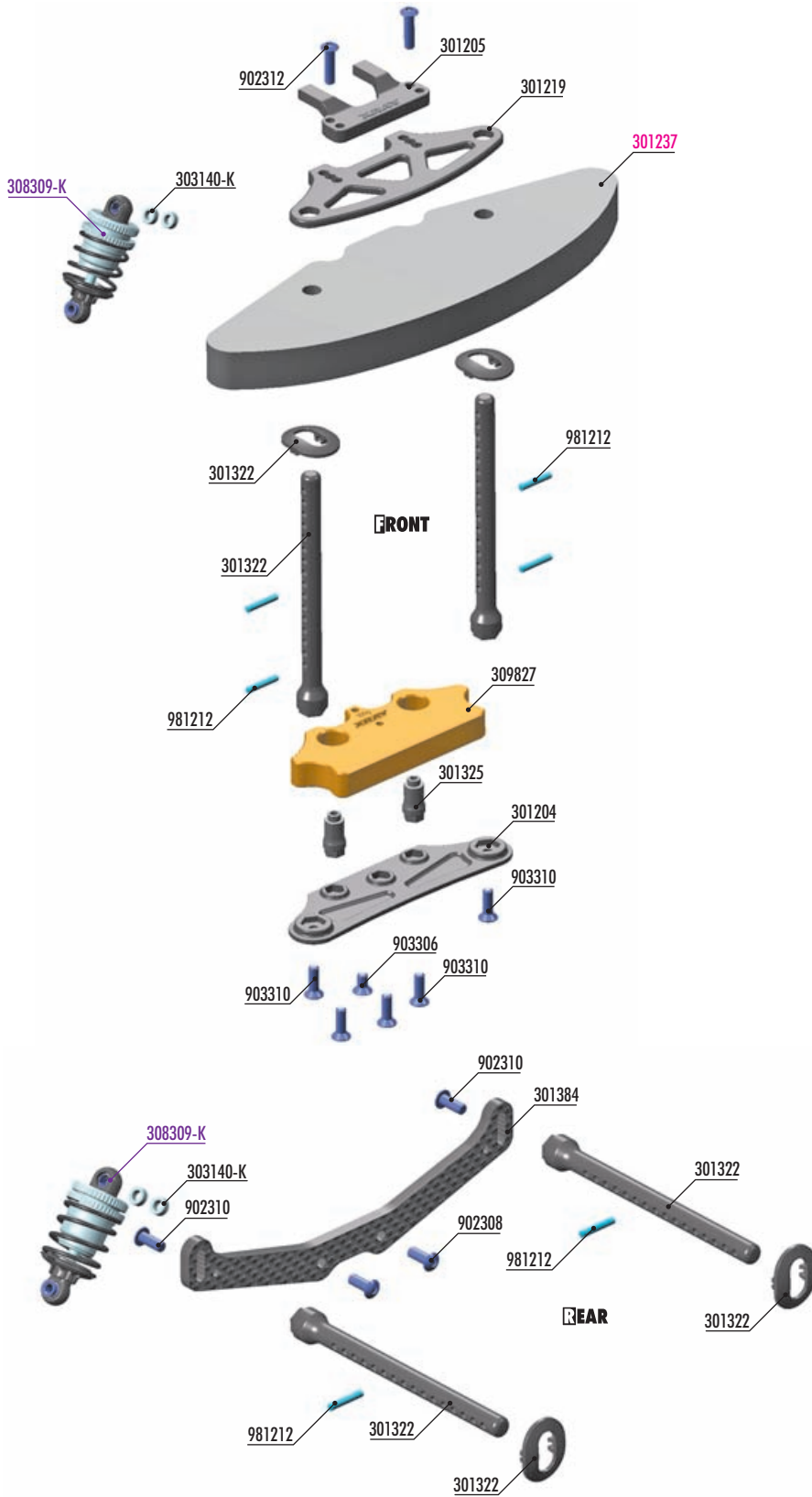

**FRONT BODY MOUNT SET**

#301322	0mm	INCLUDED
#301323	+1mm	OPTION
#301324	+2mm	OPTION

**FRONT ECC. BODY MOUNT SET**

#301326	0mm	OPTION
#301327	+1mm	OPTION
#301328	+2mm	OPTION

#301210  
**GRAPHITE UPPER HOLDER - 2.5mm**  
 (Alu shim 4x6x2mm - INCLUDED)

#309826  
**X4F WEIGHT FRONT 50+50g**

#301322-H  
**HARD COMPOSITE HORIZONTAL REAR BODY MOUNT POST - SET**

#301351-0  
**ALU ADJUSTABLE BODY POST STOP (2)**

#301351-K  
**ALU ADJUSTABLE BODY POST STOP (2)**

**BAG**

**07**

- 301204 COMPOSITE BUMPER
- 301205 X4 COMPOSITE LONGER BUMPER UPPER HOLDER BRACE
- 301219 COMPOSITE UPPER HOLDER FOR BUMPER
- 301322 FRONT BODY MOUNT SET
- 301325 COMPOSITE BRACE FOR BUMPER - LOW (2)
- 301384 X4F GRAPHITE BODY POST & BODY POST HOLDER - ONE-PIECE
- 303140-K ALU SHIM 3x5x2.0mm - BLACK (10)
- 309827 X4F BUMPER WEIGHT FRONT 100g

- 902308 HEX SCREW SH M3x8 (10)
- 902310 HEX SCREW SH M3x10 (10)
- 902312 HEX SCREW SH M3x12 (10)

- 903306 HEX SCREW SFH M3x6 (10)
- 903310 HEX SCREW SFH M3x10 (10)
- 981212 PIN 2x12 (10)

**301237 X4F FOAM BUMPER FOR 100g WEIGHT - HARD**

**308309-K XLP ALU SHOCK ABSORBER-SET - BLACK (2)**

Numbers in parentheses ( ) refer to quantities when purchased separately.

# 7. FRONT & REAR ASSEMBLY

4x 903310 SFH M3x10

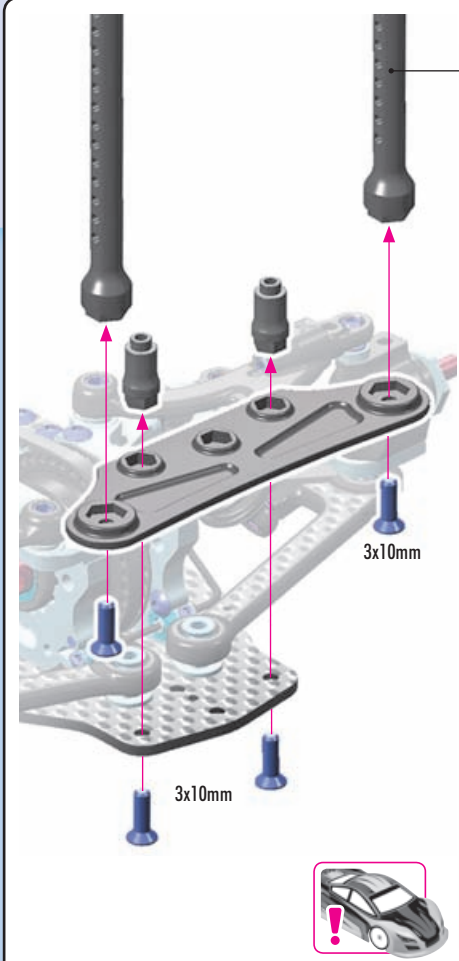

## FRONT BODY POST ORIENTATION

This new, innovative feature allows the adjustment of body position for all kind of surfaces, traction conditions, touring classes, using only one body. There are THREE different body positions possible; rearward, center, and forward. Depending on conditions, the body post positions can be easily changed which allows the body to be moved.

- The body in the **REARWARD POSITION** makes the car super stable and very easy to drive. It makes the car easier to drive in chicanes and more predictable in high-traction conditions.
- The body in the **CENTER POSITION** makes the car more aggressive and steer faster, but is a slightly more difficult to drive in low-grip conditions.
- The body in the **FORWARD POSITION** is the most aggressive. It makes the car steer a lot, but is more difficult to drive when the traction is high or when the track has a lot of chicanes.

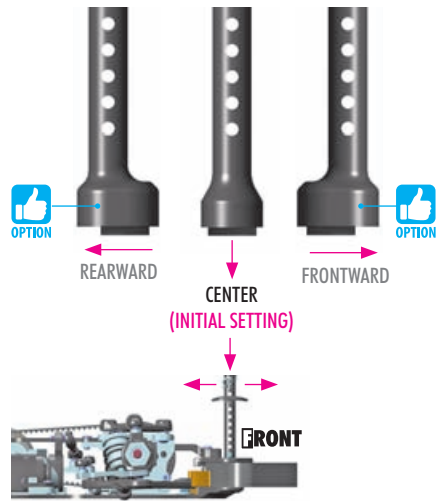

It is important to use the same body setting (rearward and center) on both front and rear body posts at the same time.

FRONT BODY MOUNT SET

#301322	0mm	INCLUDED
#301323	+1mm	OPTION
#301324	+2mm	OPTION

FRONT ECC. BODY MOUNT SET

#301326	0mm	OPTION
#301327	+1mm	OPTION
#301328	+2mm	OPTION

1x 903306 SFH M3x6

1x 903310 SFH M3x10

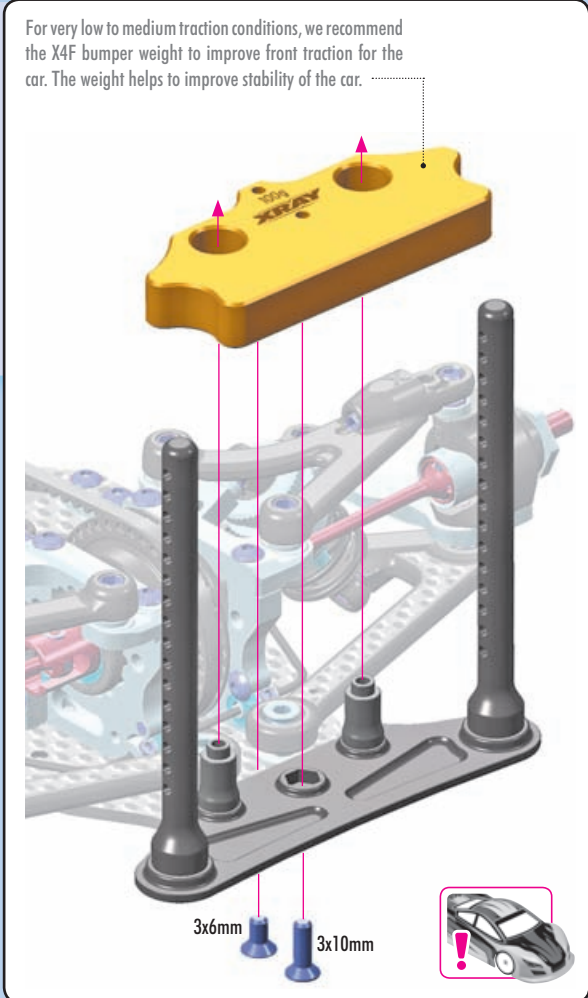

#309826 X4F WEIGHT FRONT 50+50g

Optional 2x50g chassis brass weights located under the front driveshafts along the centerline of the front suspension improve on/off-power weight transfer for better balance and rotation. Recommended for higher traction conditions as it decreases forward traction.

ASSEMBLY VIEW



# 7. FRONT & REAR ASSEMBLY

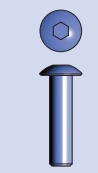

2x 902312  
SH M3x12



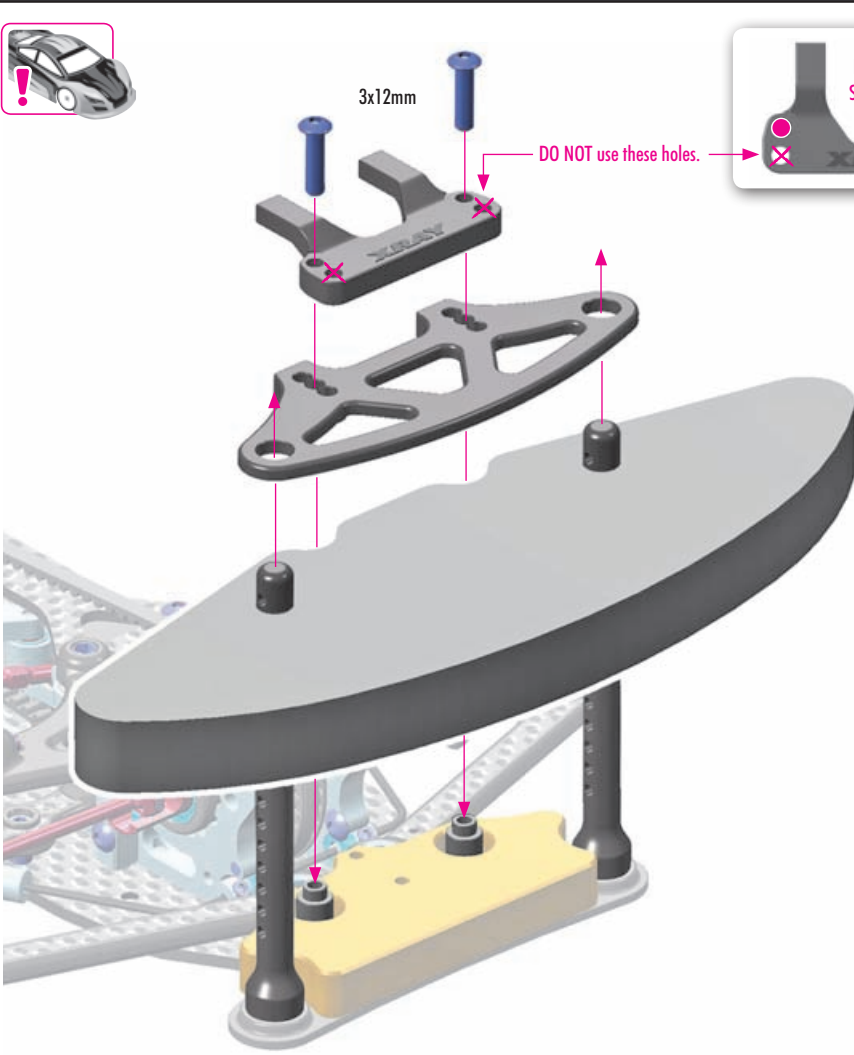



3x12mm

DO NOT use these holes.

INITIAL SETTING





INITIAL SETTING



OPTION

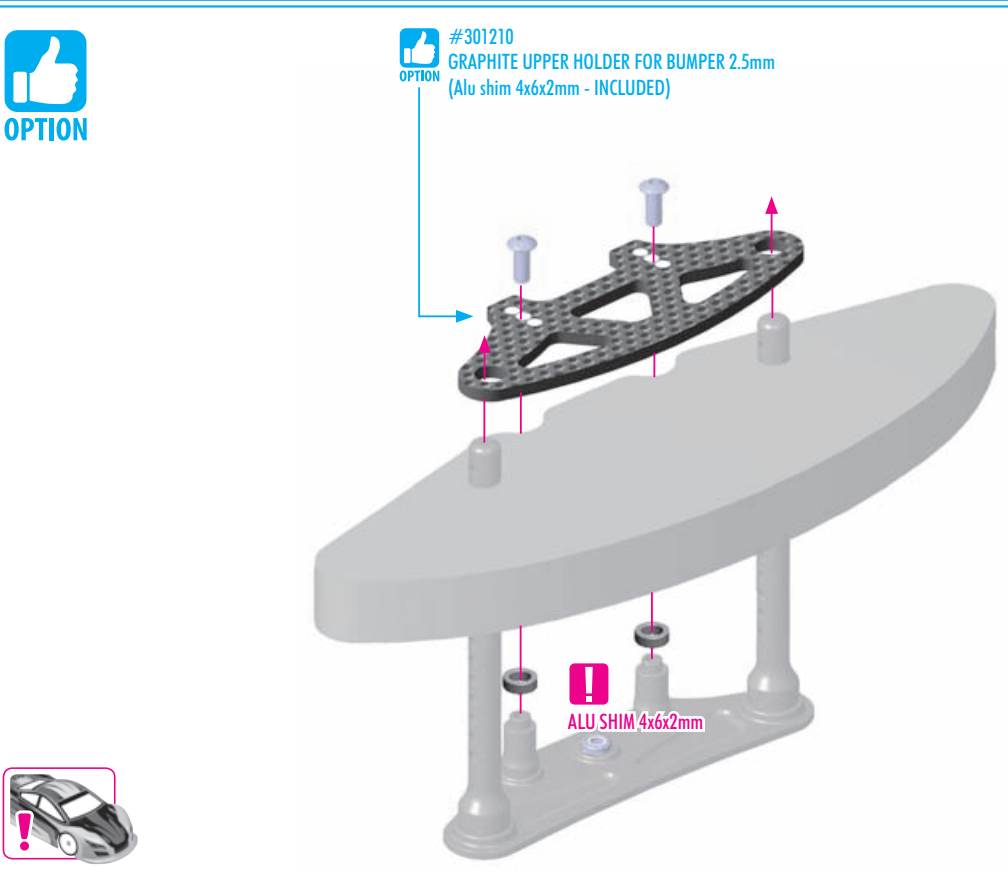



#301210  
GRAPHITE UPPER HOLDER FOR BUMPER 2.5mm  
(Alu shim 4x6x2mm - INCLUDED)

ALU SHIM 4x6x2mm

INITIAL SETTING

# 7. FRONT & REAR ASSEMBLY

4x 981212  
P 2x12

2x L=R



VIDEO TECH TIP



FRONT BODY UPSTOP SYSTEM

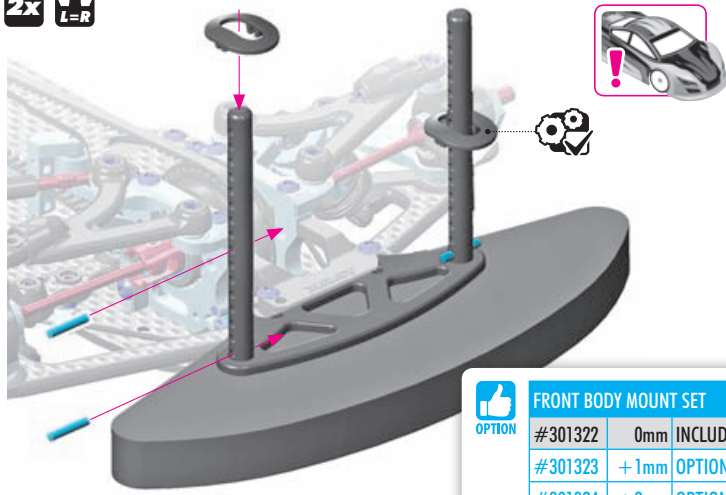

**#301351-0**  
ALU ADJUSTABLE BODY POST STOP (2)



**#301351-K**  
ALU ADJUSTABLE BODY POST STOP (2)



Very handy, easily externally adjustable body post made from Swiss 7075 T6 aluminum. Allows for adjustment of body height by 3mm without needing to change the position on the body post.

OPTION

**FRONT BODY MOUNT SET**

#301322	0mm	INCLUDED
#301323	+1mm	OPTION
#301324	+2mm	OPTION

OPTION

**FRONT ECC. BODY MOUNT SET**

#301326	0mm	OPTION
#301327	+1mm	OPTION
#301328	+2mm	OPTION

4x 303140-K  
SHIM 3x5x2



VIDEO TECH TIP



SHOCKS & SPRINGS

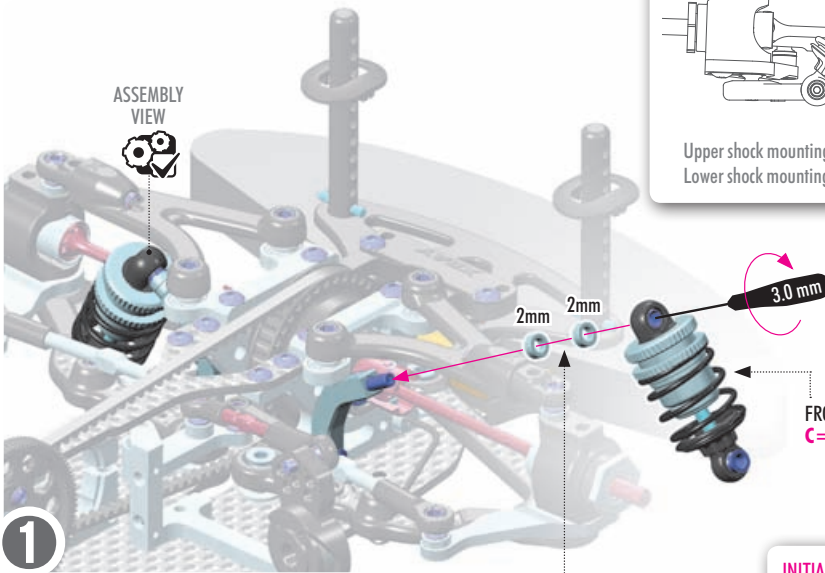

X4F'24 / X4F'25

The new shock mounting system uses shims for more precise shock angle adjustment.

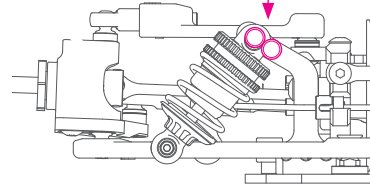

The following settings will duplicate X4F'24/X4F'25 shock angles:

Upper shock mounting position on shock tower on X4F'24 = 4mm shim on X4F'25  
Lower shock mounting position on shock tower on X4F'24 = 2mm shim on X4F'25

1

2

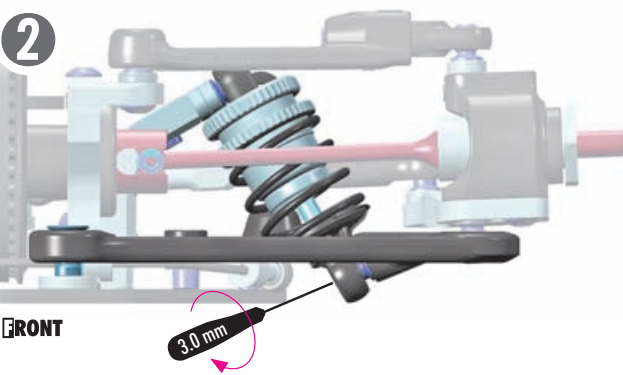

FRONT SHOCK SPRING  
C=2.5-2.8

INITIAL SETTING

4mm shims - CARPET TRACKS

L=R

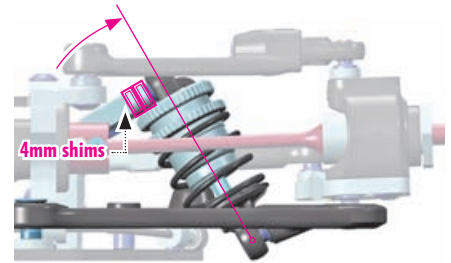

INITIAL SETTING

2mm shim - ASPHALT TRACKS

L=R

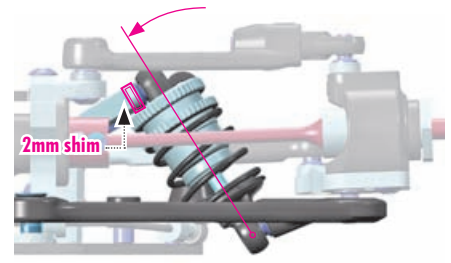

OPTION

**#308029**  
XLP ALU PROGRESSIVE SHOCK SYSTEM - SET (2)



The progressive shock inserts improve steering characteristics. The XLP PSS set fits the stock XLP shock bodies included in the kit. Must be used with #308026 - XLP Progressive Pistons.



OPTION

**#308026**  
XLP COMPOSITE 2-HOLE ø0.8mm PROGRESSIVE PISTON (4)



# 7. FRONT & REAR ASSEMBLY

- 2x 902308 SH M3x8
- 2x 902310 SH M3x10
- 2x 981212 P 2x12

**ASSEMBLY VIEW**

3x10mm

3x8mm

1

2

The graphite body post holder has 6 POSITIONS, spaced 1.1mm between each, for precise and easy adjustment.

**VIDEO TECH TIP**

**REAR BODY POST MOUNTING**

**#301351-0**  
ALU ADJUSTABLE BODY POST STOP (2)  
OPTION

**#301351-K**  
ALU ADJUSTABLE BODY POST STOP (2)  
OPTION

Very handy, easily externally adjustable body post made from Swiss 7075 T6 aluminum. Allows for adjustment of body height by 3mm without needing to change the position on the body post.

**#301322-H**  
HARD COMPOSITE HORIZONTAL REAR BODY MOUNT POST - SET  
OPTION

Optional HARD posts eliminates the flex of the horizontal mounting. Use these posts only for horizontal body mounting.

Optional horizontal rear body mounting has shown benefits on medium to high grip conditions, especially on technical tracks, by improving directional changes, steering response and rotation. Note that rear grip is also reduced, so may be useful in Stock or Super Stock spec class racing.

**X4F'24 / X4F'25**

The new shock mounting system uses shims for more precise shock angle adjustment.

The following settings will duplicate X4F'24/X4F'25 shock angles:

Upper shock mounting position on shock tower on X4F'24 = 4mm shim on X4F'25

Lower shock mounting position on shock tower on X4F'24 = 2mm shim on X4F'25

- 4x 303140-K SHIM 3x5x2

**INITIAL SETTING**  
4mm shims - CARPET TRACKS

L=R

4mm shims

**INITIAL SETTING**  
2mm shims - ASPHALT TRACKS

L=R

2mm shim

**ASSEMBLY VIEW**

REAR

REAR SHOCK SPRING  
C=2.6

3.0mm

2mm 2mm

1

2

3.0mm

**VIDEO TECH TIP**

**SHOCK SHIMMING TUTORIAL**

**#308029**  
XLP ALU PROGRESSIVE SHOCK SYSTEM - SET (2)  
OPTION

The progressive shock inserts improve steering characteristics. The XLP PSS set fits the stock XLP shock bodies included in the kit. Must be used with #308026 - XLP Progressive Pistons.

**#308026**  
XLP COMPOSITE 2-HOLE ø0.8mm PROGRESSIVE PISTON (4)  
OPTION



# 7. FINAL ASSEMBLY

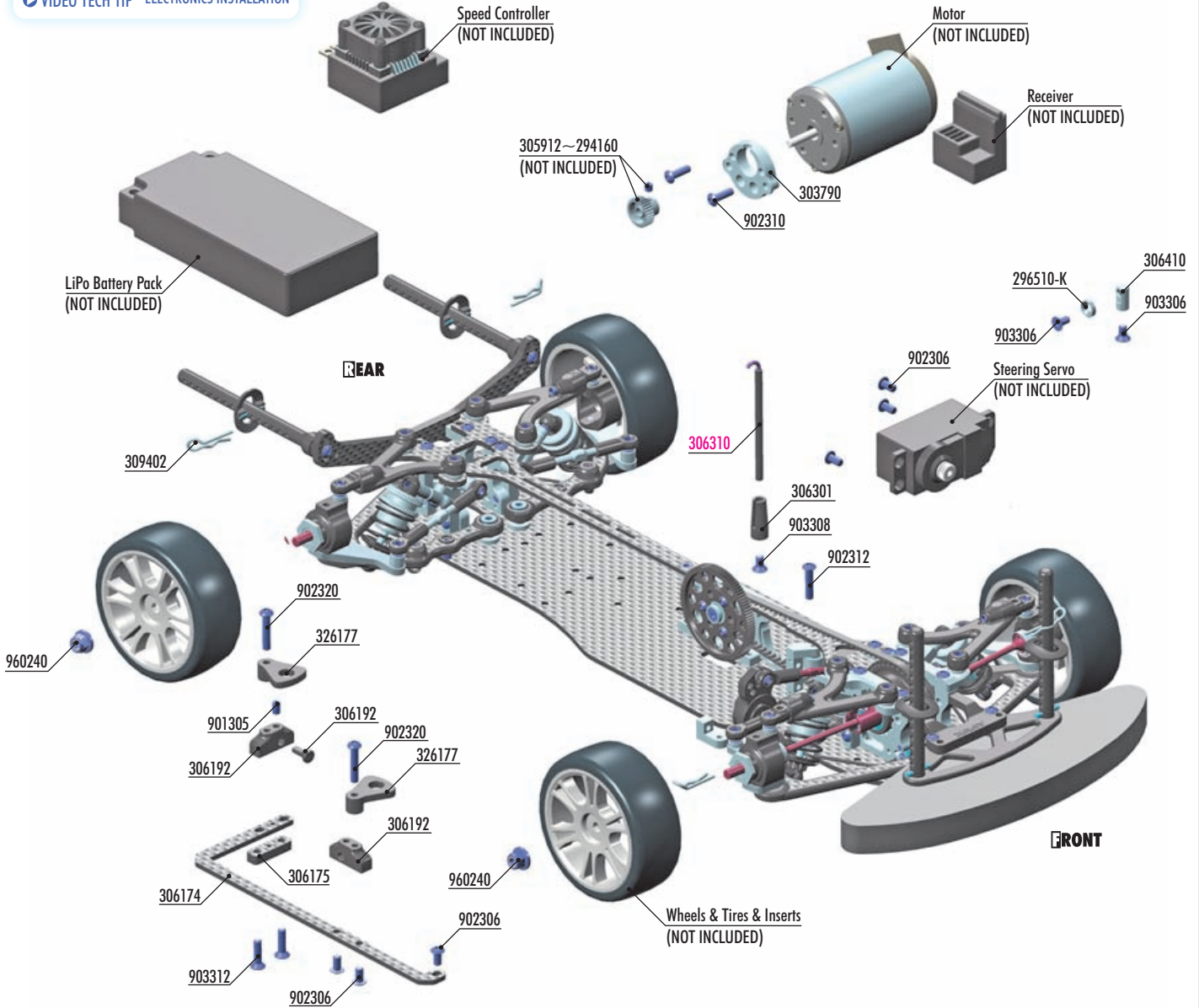

**OPTION** HUDY ALU RC FAN 30mm & 40mm (on page 43)



**OPTION** TUNGSTEN & STAINLESS STEEL WEIGHTS (on page 42 and 45)



**OPTION** #306410 ALU FAN MOUNT



**OPTION** ALU REAR WING SHIM

#	COLOR	BRAND	OPTION
#353561	SILVER	XRAY	OPTION
#293561	SILVER	HUDY	OPTION
#293561-K	BLACK	HUDY	OPTION
#293561-O	ORANGE	HUDY	OPTION



**BAG**

**07**

305912~294160 NARROW ALU PINION GEAR 12T~60T (OPTION)

- 296510-K ALU COUNTERSUNK SHIM - BLACK (10)
- 303790 ALU ECCENTRIC MOTOR BULKHEAD INSERT
- 306174 X4F GRAPHITE BATTERY HOLDER - ONE-PIECE
- 306175 GRAPHITE BATTERY PLATE SHIM (2)
- 306192 COMPOSITE ADJUSTABLE BATTERY HOLDER & BACKSTOP (2+2)
- 306301 ANTENNA MOUNT - THIN
- 306410 ALU UNIVERSAL MOUNT
- 309402 BODY CLIP FOR 6mm BODY POST (4)
- 326177 COMPOSITE BATTERY CLAMP (2)

- 901305 HEX SCREW SB M3x5 (10)
- 902306 HEX SCREW SH M3x6 (10)
- 902310 HEX SCREW SH M3x10 (10)
- 902312 HEX SCREW SH M3x12 (10)
- 902320 HEX SCREW SH M3x20 (10)
- 903306 HEX SCREW SFH M3x6 (10)
- 903308 HEX SCREW SFH M3x8 (10)
- 903312 HEX SCREW SFH M3x12 (10)
- 960240 NUT M4 WITH SERRATED FLANGE (10)

306310 ANTENNA (2)

Numbers in parentheses ( ) refer to quantities when purchased separately.

# 7. FINAL ASSEMBLY

**! SERVO WIRE**  
The motor mount features a cut-out for the servo wire to pass underneath.

**! SERVO WIRE**  
**(Untight the motor mount screws)**  
The motor mount features a cut-out for the servo wire to pass underneath. When installing servo, loosen the motor mount, place the servo wire in the groove, and then tighten the motor mount and top deck.

**3x** 902306  
SH M3x6

**VIDEO TECH TIP**

STEERING SYSTEM

**From Servo**

3x6mm ②

3x6mm ②

① ④

3x5x1mm Shim

3x7x1mm Shims

**SERVO AND SERVO SAVER POSITION ADJUSTMENT.**  
Due to variations in servo sizes, shims may be required to provide proper clearance and alignment between the servo, servo saver and servo mount.

- Use 3x5x1mm size shims between the servo and servo saver to move the servo saver out from servo mount.
- Use 3x7x1mm size shims between servo and servo mount to move the servo more back.

**! CAN NOT touch.**

**! DETAIL**

Attach servo arm to servo output shaft using screw from servo. Servo saver must be perpendicular to chassis when servo is in neutral.



# 7. FINAL ASSEMBLY

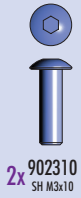

2x 902310  
SH M3x10

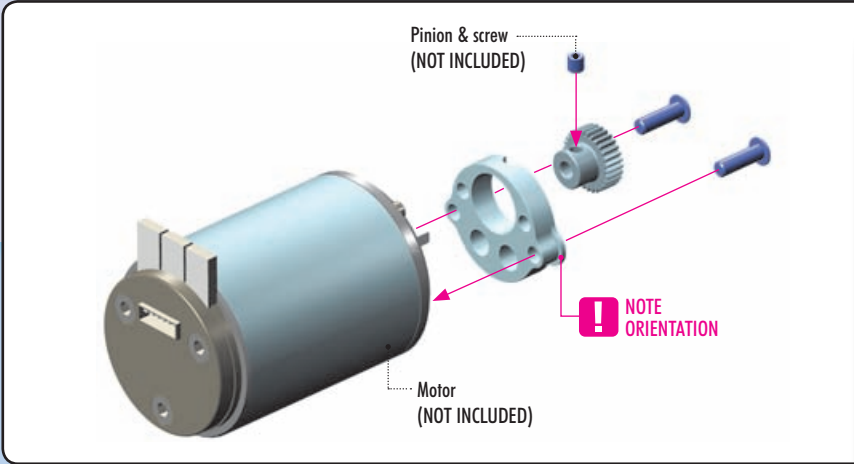

## ALU PINION GEARS (OPTION)

#305912 12T / 48P	#305968 18T / 64P
#305913 13T / 48P	#305969 19T / 64P
#305914 14T / 48P	#305970 20T / 64P
#305915 15T / 48P	#305971 21T / 64P
#305916 16T / 48P	#305972 22T / 64P
#294017 17T / 48P	#305973 23T / 64P
#305918 18T / 48P	#305974 24T / 64P
#294019 19T / 48P	#305975 25T / 64P
#294020 20T / 48P	#294126 26T / 64P
#294021 21T / 48P	#294127 27T / 64P
#294022 22T / 48P	#294128 28T / 64P
#294023 23T / 48P	#294129 29T / 64P
#294024 24T / 48P	#294130 30T / 64P
#305925 25T / 48P	#294131 31T / 64P
#305926 26T / 48P	#294132 32T / 64P
#305927 27T / 48P	#294133 33T / 64P
#305928 28T / 48P	#305984 34T / 64P
#305929 29T / 48P	#305985 35T / 64P
#294030 30T / 48P	#294136 36T / 64P
#305931 31T / 48P	#294137 37T / 64P
#305932 32T / 48P	#294138 38T / 64P
#294033 33T / 48P	#294139 39T / 64P
#305934 34T / 48P	#294140 40T / 64P
#294035 35T / 48P	#294141 41T / 64P
	#294142 42T / 64P
	#294143 43T / 64P
	#294144 44T / 64P
	#294145 45T / 64P
	#294146 46T / 64P
	#294147 47T / 64P
	#294148 48T / 64P
	#294149 49T / 64P
	#294150 50T / 64P
	#294152 52T / 64P
	#294154 54T / 64P
	#294156 56T / 64P
	#294158 58T / 64P
	#294160 60T / 64P

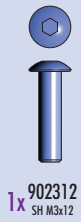

1x 902312  
SH M3x12

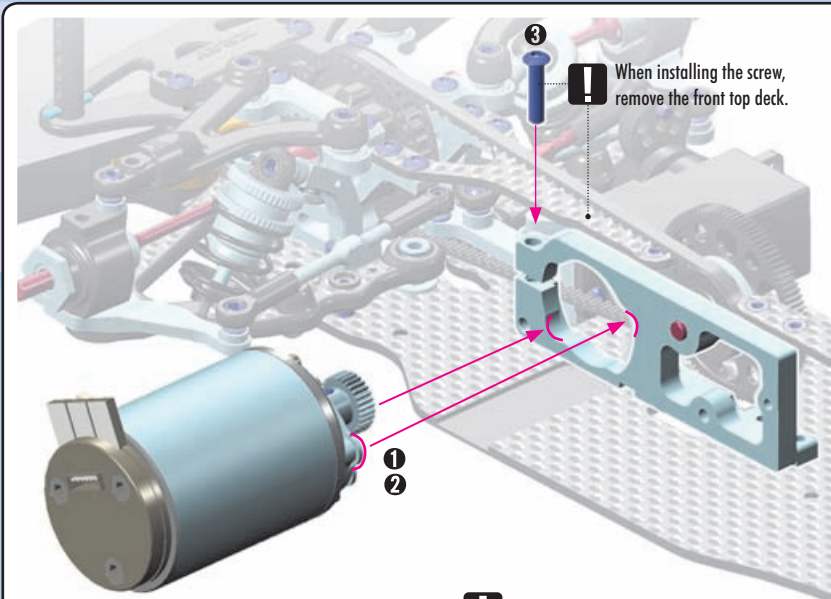

The most-used FWD ratios are 4.5 and 5. Use these recommended spur gears and pinions to achieve the desired ratio.

4.5 ratio - 90T spur / 38T pinion  
5 ratio - 100T spur / 38T pinion

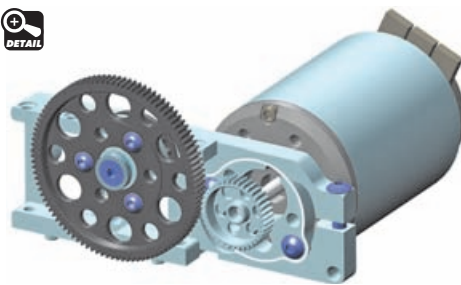

1 Attach the motor to the eccentric motor holder in the indicated orientation. Tighten the mounting screws.

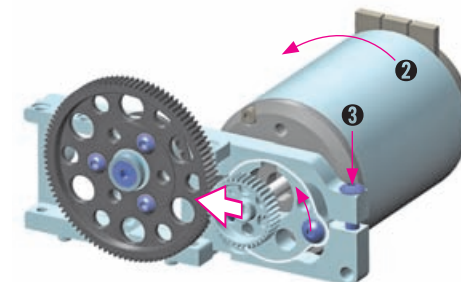

2 Adjust the gear mesh by rotating the eccentric motor holder.

3 Tighten the clamp screw.

2 Adjust the motor so the pinion meshes with the spur gear properly. Make sure the gear mesh is NOT too tight. There should be a small amount of play between the teeth of the pinion gear and the spur gear.



# 7. FINAL ASSEMBLY

1x 903308 SFH M3x8

VIDEO TECH TIP

WEIGHT BALANCE

ELECTRONICS INSTALLATION

Receiver (NOT INCLUDED)

Speed Controller (NOT INCLUDED)

NOTE: If the antenna tube DOES NOT hold the antenna properly, apply a small drop of the CA glue to the outside end of the antenna tube while inserting it into the holder. Make sure NOT to apply glue to the inside of the antenna tube, or the antenna wire will get permanently stuck.

Feed the receiver wire into the antenna tube.

Double-sided Tape HUDY #107875 (NOT INCLUDED)

3x8mm

OPTION

## FORWARD ALU FAN MOUNT ALTERNATIVE

There are two options how to mount the fan mount depending of the style and size of the fan. Either in front or behind the motor. If you are using HUDY fan, we recommend to use FORWARD mount as it keeps the weight of the car as much in front as possible.

#306410 ALU FAN MOUNT

#902318 SH M3x18

10.5mm

#333074 ALU MOUNT 3x6x10.5mm (2)

#293101 HUDY ALU RC FAN 30MM - SIDE MOUNT 2 HOLE

#293110 HUDY BRUSHLESS RC FAN 30mm WITH EXTERNAL SOLDERING TABS

#293111 HUDY BRUSHLESS RC FAN 40mm WITH EXTERNAL SOLDERING TABS

#293112 HUDY BRUSHLESS RC FAN 30mm WITH INTERNAL SOLDERING TABS

#293113 HUDY BRUSHLESS RC FAN 40mm WITH INTERNAL SOLDERING TABS

## REARWARD ALU FAN MOUNT ALTERNATIVE

#306410 ALU FAN MOUNT

2x 901305 SB M3x5

2x 902320 SH M3x20

VIDEO TECH TIP

BATTERY MOUNTING SYSTEM

3x20mm

3x5mm

NOTE ORIENTATION

To ensure correct functioning of the battery holder, DO NOT overtighten the screw; the holder must be able to move.

HEIGHT ADJUSTMENT  
1 turn = 0.5mm

# 7. FINAL ASSEMBLY



3x 902306  
SH M3x6



2x 903306  
SFH M3x6



2x 903312  
SFH M3x12

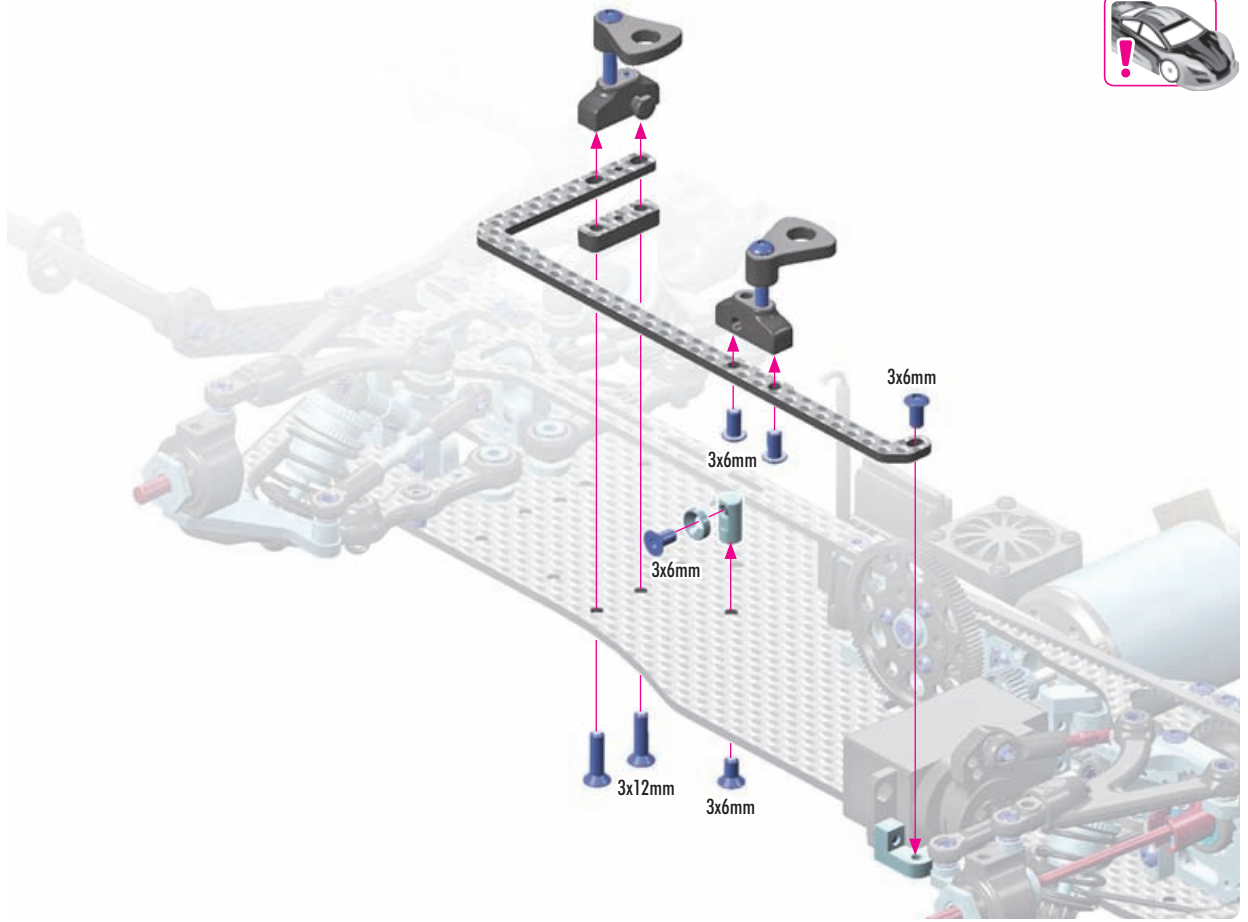

VIDEO TECH TIP



WEIGHT BALANCE

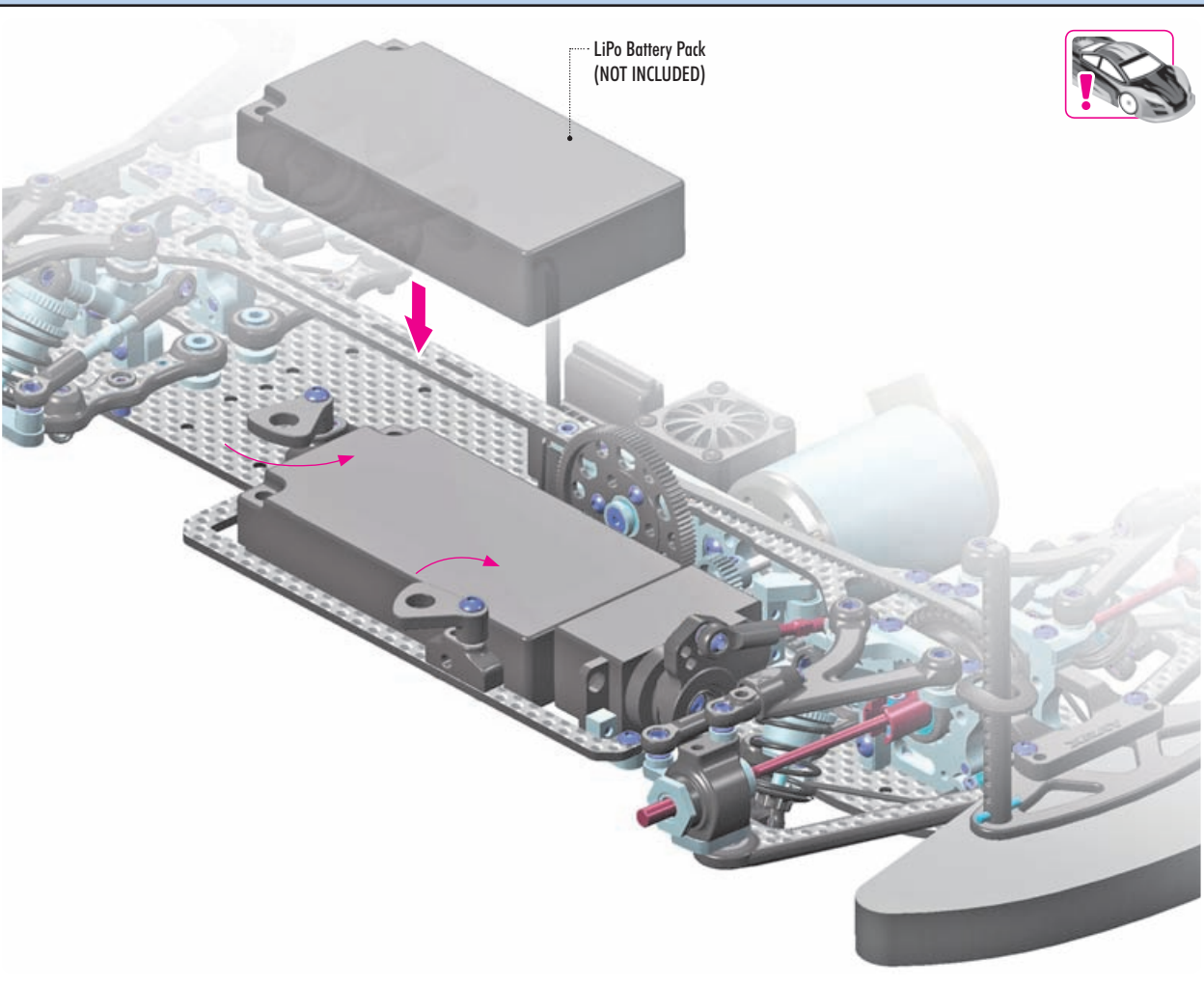

VIDEO TECH TIP



BATTERY MOUNTING SYSTEM



# 7. FINAL ASSEMBLY

**BATTERY BACKSTOP**

The new adjustable battery backstop system secures the battery in the car in a tweak-free, non-fixed manner to help improve traction and makes it more stable and easier to drive.

It is very important that battery has a very small amount of play in all directions so it does NOT tweak the car, but the play cannot be too much otherwise the battery may fall out in crashes.

Due to different battery sizes used on carpet and asphalt, there are multiple battery mounting possibilities.

- Standard Height Battery pack
- LCG Battery pack
- Short Battery pack
- Long Battery pack

Backstop orientation

4x #960240 N M4

VIDEO TECH TIP

TRACK WIDTH (OFFSET)

DOWNSTOP & RIDE HEIGHT

Make sure the wheel nuts are very tight, so the wheels DO NOT loosen during operation.

ALU REAR WING SHIM			
OPTION #353561	SILVER	XRAY	OPTION
#293561	SILVER	HUDDY	OPTION
#293561-K	BLACK	HUDDY	OPTION
#293561-O	ORANGE	HUDDY	OPTION

OFFSET ALU WHEEL SHIMS		
OPTION #305380	0.75mm	OPTION
#305382	0.5mm	OPTION
#305381	1.0mm	OPTION

NUT M4 WITH SERRATED FLANGE		
OPTION #960240	SILVER	INCLUDED
#960241-K	ALU BLACK	OPTION
#960241-O	ALU ORANGE	OPTION

OPTION #803041 HUDDY 1/10 PRE-CUT SLICK TIRES RIGHT & LEFT (2+2)





**BODY STOP SYSTEM**

The X4F features an adjustable front body upstop system incorporated into the new upper arm to prevent the body shell from bottoming out and hitting the ground during cornering. When the system is set correctly, it allows the body to be run lower without dragging on the ground to improve aerodynamic efficiency.



**BODY STOP ALTERNATIVE**  
with screw and ball joint  
(#901308 SB M3x8mm / #303457 Ball Joint)

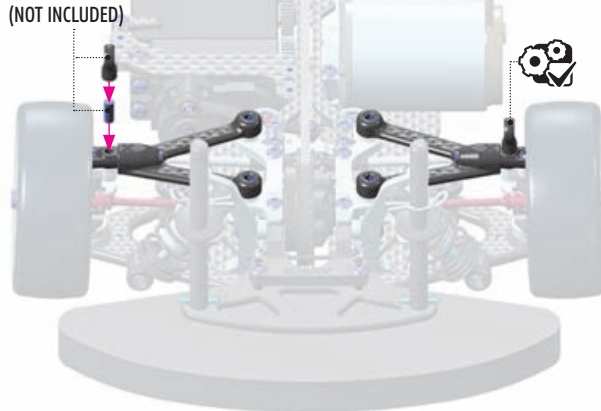

**BODY STOP ALTERNATIVE**  
with screw  
(#902316 SH M3x16mm)

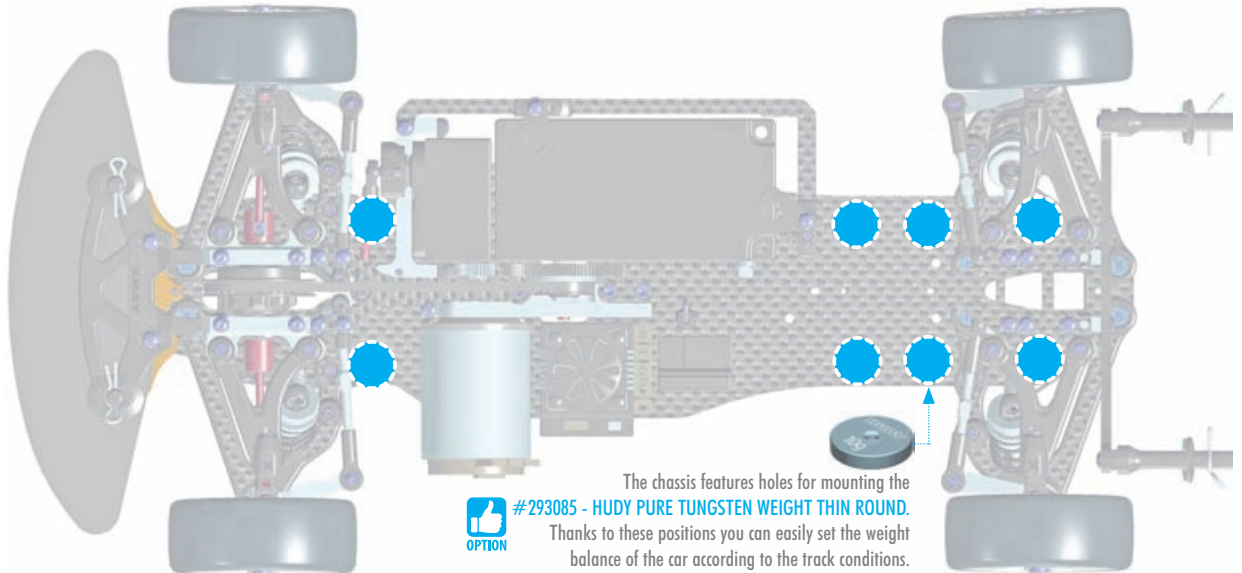
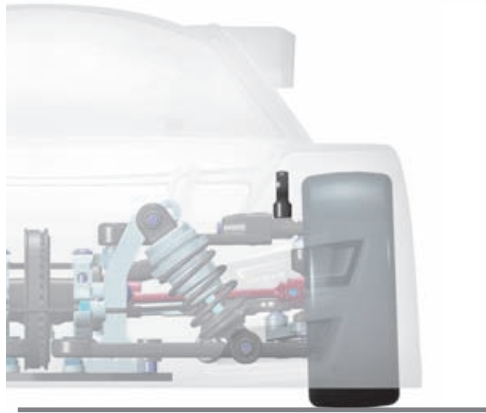
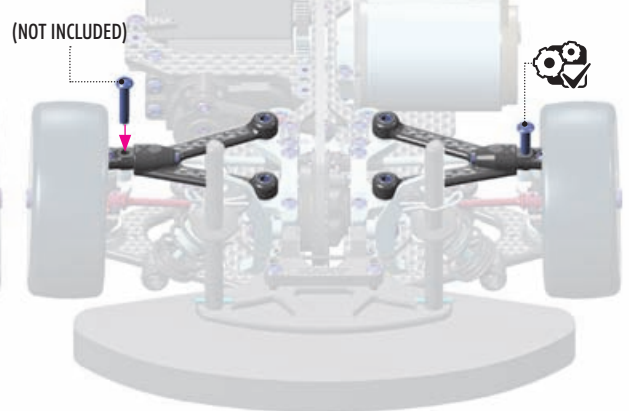

#293085 - HUDY PURE TUNGSTEN WEIGHT THIN ROUND.  
Thanks to these positions you can easily set the weight balance of the car according to the track conditions.



#326181  
STAINLESS STEEL  
BATTERY WEIGHT 35g



#293083  
HUDY PURE TUNGSTEN  
WEIGHT 15g



#293085  
HUDY PURE TUNGSTEN  
WEIGHT THIN ROUND  
WITH M3 - 10g



#293081  
HUDY PURE TUNGSTEN  
WEIGHT 5g



#293082  
HUDY PURE TUNGSTEN  
WEIGHT 10g



VIDEO TECH TIP

REAR BODY POST MOUNTING

VIDEO TECH TIP

CHASSIS TWEAK

EXCLUSIVE PROFESSIONAL

# HUDY

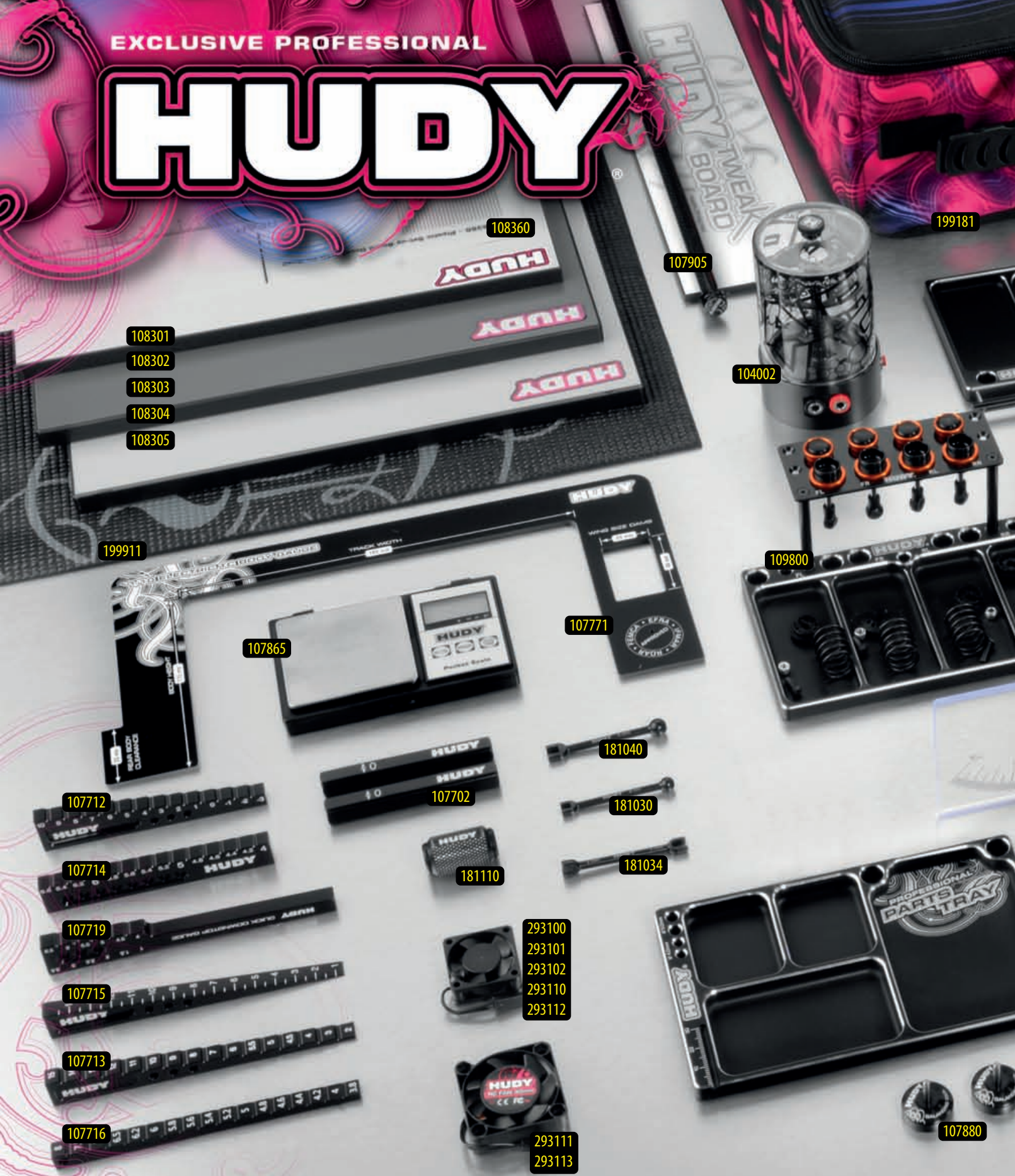

104002 HUDY AIR VAC - VACUUM PUMP - ON-ROAD  
 106260 HUDY TIRE ADDITIVE - TIRE GRIPPER - 50ML - V2  
 107090 HUDY BEARING CHECKING TOOL  
 107601 LIMITED EDITION - REAMER FOR BODY 0-9MM + COVER - SMALL  
 107643 LIMITED EDITION - ARM REAMER # 3.0MM  
 107702 CHASSIS DROOP GAUGE SUPPORT BLOCKS FOR 1/10 (2)  
 107712 CHASSIS DROOP GAUGE -3.0-10MM FOR 1/10 CARS (10MM)  
 107713 CHASSIS RIDE HEIGHT GAUGE STEPPED 2.0-15.0MM  
 107714 ULTRA-FINE CHASSIS DROOP GAUGE 4.0-6.6MM  
 107715 CHASSIS RIDE HEIGHT GAUGE 1.0-15.0MM (BEVELED)  
 107716 ULTRA-FINE CHASSIS RIDE HEIGHT GAUGE 3.8-8.0MM  
 107719 QUICK DOWNSTOP GAUGE TOOL 1.0-6.5MM  
 107720 CHASSIS RIDE HEIGHT GAUGE 30-17MM FOR 1/8 & 1/10 OFF-ROAD  
 107750 HUDY GRAPHITE QUICK CAMBER GAUGE 1.5°, 2°, 2.5° FOR 1/10 TC

107771 HUDY BODY GAUGE 1/10 ELECTRIC TOURING CARS  
 107855 HUDY PIT LED  
 107865 HUDY PROFESSIONAL DIGITAL POCKET SCALE 300G/0.01G  
 107870 HUDY FIBRE-REINFORCED TAPE - BLACK  
 107875 HUDY ULTRA DOUBLE-SIDED TAPE  
 107880 CHASSIS BALANCING TOOL (2)  
 107904 HUDY QUICK-TWEAK STATION 1/10 & 1/12 ON-ROAD  
 107905 HUDY TWEAK BOARD SET  
 108150 HUDY 1/10 TOURING CAR STAND - V3  
 108190 HUDY ALU PARTS TRAY 160x100MM  
 108192 HUDY ALU PARTS TRAY NARROW 215x50MM  
 108193 HUDY ALU PARTS TRAY LARGE 215x100MM  
 108301 FLAT SET-UP BOARD 1/10 & 1/12 - LIGHTWEIGHT - GREY  
 108302 FLAT SET-UP BOARD 1/10 & 1/12 - LIGHTWEIGHT - SILVER GREY

108303 FLAT SET-UP BOARD 1/10 & 1/12 - LIGHTWEIGHT - BLACK  
 108304 FLAT SET-UP BOARD 1/10 & 1/12 - LIGHTWEIGHT - RED  
 108305 FLAT SET-UP BOARD 1/10 & 1/12 - LIGHTWEIGHT - BLUE  
 108360 PLASTIC SET-UP BOARD DE  
 109301 HUDY SET-UP STATION FOR  
 109360 ALU NUT FOR 1/10 TOURING  
 109370 ALU SET-UP WHEEL FOR 1/10  
 109800 HUDY ALU TRAY FOR ON-ROAD  
 109840 HUDY ALU TRAY FOR 1/10  
 109860 HUDY ALU TRAY FOR SET-UP  
 109880 HUDY ALU TRAY FOR ACCESSORIES  
 111545 LIMITED EDITION - ALLEN  
 112045 LIMITED EDITION - ALLEN  
 113045 LIMITED EDITION - ALLEN





& 1/12 - LIGHTWEIGHT - DARK GREY  
 & 1/12 - LIGHTWEIGHT - TITAN  
 & 1/12 - LIGHTWEIGHT - BLACK  
 CAL 282X386MM - 1/10 TC  
 R 1/10 TOURING CARS  
 G SET-UP SYSTEM (4)  
 10 RUBBER TIRES (4)  
 ROAD DIFF & SHOCKS  
 OFF-ROAD DIFF ASSEMBLY  
 IP SYSTEM  
 SSORIES & PIT LED  
 WRENCH # 1.5MM  
 WRENCH # 2.0MM  
 WRENCH # 3.0MM

132045 LIMITED EDITION - ALLEN WRENCH + BALL REPL. TIP # 2.0MM  
 175535 LIMITED EDITION - SOCKET DRIVER # 5.5MM  
 177035 LIMITED EDITION - SOCKET DRIVER # 7.0MM  
 181030 HUDY SPRING STEEL TURNBUCKLE WRENCH 3 MM  
 181034 TURNBUCKLE WRENCH 3 & 4MM - HUDY SPRING STEEL™  
 181040 TURNBUCKLE WRENCH 4MM - HUDY SPRING STEEL™  
 181110 HUDY BALL JOINT WRENCH  
 183011 HUDY PROFESSIONAL MULTI TOOL  
 188981 HUDY POCKET HOBBY KNIFE  
 188990 HUDY PROFESSIONAL BODY SCISSORS  
 199060 HUDY ALU TOOL STAND  
 199181 HUDY CAR BAG - 1/10 ON-ROAD - TC - PAN CAR - CUSTOM NAME  
 199270 HUDY LIPO SAFETY BAG - CUSTOM NAME  
 199911 HUDY PIT MAT ROLL 750x1200MM WITH PRINTING

293100 HUDY ALU RC FAN 30MM - BOTTOM MOUNT 2 HOLE  
 293101 HUDY ALU RC FAN 30MM - SIDE MOUNT 2 HOLE  
 293102 HUDY ALU RC FAN 30MM - TOP/SIDE MOUNT 4 HOLE  
 293110 HUDY BRUSHLESS RC FAN 30mm - WITH EXTERNAL SOLDERING TABS  
 293111 HUDY BRUSHLESS RC FAN 40mm - WITH EXTERNAL SOLDERING TABS  
 293112 HUDY BRUSHLESS RC FAN 30mm - WITH INTERNAL SOLDERING TABS  
 293113 HUDY BRUSHLESS RC FAN 40mm - WITH INTERNAL SOLDERING TABS  
 298100 HUDY TIN ROUND BOX 80x30mm

For more information about tools, set-up equipment and accessories suitable for your car please visit:

[www.hudy.net](http://www.hudy.net)





EXCLUSIVE PROFESSIONAL

# HUDY

# HUDY

199295-H

199290-H

106261

106200

803041

107861

107840

105590

107846

107761

106290

293080

293012

293011

293083

293082

293081

293084

294017~294035

294127~294160

- |        |   |        |   |
|--------|---|--------|---|
| 107761 | HUDY ADJUSTABLE CAMBER GAUGE 80MM                                 | 105590 | HUDY WHEEL BALANCING PUTTY                                      |
| 107772 | HUDY PROFESSIONAL 1/10 TC WHEEL ARCH MARKER + WHEEL ADAPTER & NUT | 181090 | HUDY SPECIAL TOOL FOR TURNBUCKLES & NUTS                        |
| 106210 | HUDY GRAPHITE GREASE  | 181091 | HUDY TURNBUCKLE WRENCH 3 & 4MM - V2                             |
| 106230 | HUDY BEARING OIL  | 803041 | HUDY 1/10 PRE-CUT SLICK TIRES RIGHT & LEFT (2+2)                |
| 106200 | HUDY MAGIC CLEANING GUM   | 293011 | HUDY STAINLESS STEEL BATTERY WEIGHT 35G                         |
| 106261 | HUDY TIRE ADDITIVE - TIRE GRIPPER RED - 50ML                      | 293012 | HUDY STAINLESS STEEL BATTERY WEIGHT FOR NARROW BATTERY PACK 35G |
| 106350 | HUDY PREMIUM SILICONE OIL 500 CST - 50ML                          | 293080 | LEAD WEIGHTS 4x5G & 4x10G WITH 3M GLUE                          |
| 107861 | HUDY PROFESSIONAL RACING STOPWATCH XL DISPLAY                     | 293081 | HUDY PURE TUNGSTEN WEIGHT 5G                                    |
| 106290 | HUDY PROFESSIONAL SOLDER 3M LENGTH                                | 293082 | HUDY PURE TUNGSTEN WEIGHT 10G                                   |
| 107840 | CLEANING BRUSH LARGE - SOFT                                       | 293083 | HUDY PURE TUNGSTEN WEIGHT 15G                                   |
| 107846 | CLEANING BRUSH SMALL - SOFT                                       | 293084 | PRECISION BALANCING CHASSIS WEIGHT 10G (4)                      |
| 105520 | WHEEL ADAPTER FOR 1/10 ON-ROAD & 1/10 OFF-ROAD - 12MM             | 293311 | GRAPHITE REAR WING SIDE PLATE 0.5MM - 1/10 ELECTRIC (2)         |





199280M-H



199296-H



298015



105520

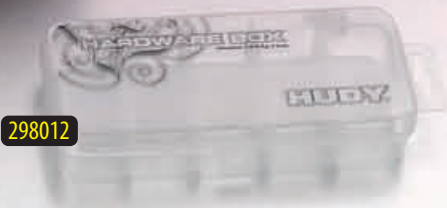

298012



298016



298018



298019



107772



298017



298014



181090



106310~106694



293311



298013



106210



106230



293491~293493

293401~293403

293497~293499

293404~293406

293501~293503

293407~293409



181091



- 293403 ALU CLAMP SERVO HORN - FUTABA, SAVÖX - OFFSET 1-HOLE M3 - 25T
- 293493 ALU SERVO HORN - FUTABA, SAVÖX - OFFSET 1-HOLE M3 - 25T - V2
- 294023 HUDY ALU ULTRA-LIGHT PINION GEAR - HARD COATED - 23T / 48
- 294140 HUDY ALU ULTRA-LIGHT PINION GEAR - HARD COATED - 40T / 64
- 294156 HUDY ALU ULTRA-LIGHT PINION GEAR - HARD COATED - 56T / 64
- 298012 HUDY PARTS BOX - 10-COMPARTMENTS
- 298013 HUDY SPRINGS BOX - 10-COMPARTMENTS
- 298014 HUDY PARTS BOX - 8-COMPARTMENTS
- 298015 HUDY PARTS CASE - 290 x 195MM
- 298016 HUDY TINY HARDWARE BOX - 4-COMPARTMENTS
- 298017 HUDY TINY ONE-PIECE HARDWARE BOX - 8-COMPARTMENTS
- 298018 HUDY TINY HARDWARE BOX - 8-COMPARTMENTS

- 298019 HUDY DIFF BOX - 8-COMPARTMENTS
- 199280M-H HUDY HARD CASE - 140x110x95MM - OIL BAG MEDIUM
- 199290-H HUDY HARD CASE - 235x190x75MM - ACCESSORIES / ENGINE BAG
- 199295-H HUDY HARD CASE - 280x150x85MM - ACCESSORIES BAG LARGE
- 199296-H HUDY HARD CASE - 120x85x46MM - ACCESSORIES / STOP WATCH

For more information about tools, set-up equipment & accessories suitable for your car please visit:

[www.hudy.net](http://www.hudy.net)



[www.teamxray.com](http://www.teamxray.com)

**XRAY EUROPE**

XRAY, K VÝSTAVISKU 6992, 91101 TRENCIN, SLOVAKIA, EUROPE  
 PHONE: +421-32-740 11 00, FAX: +421-32-740 11 09, [info@teamxray.com](mailto:info@teamxray.com)

**XRAY USA**

RC AMERICA, 2030 Century Center Blvd #15, Irving, TX 75062, USA  
 PHONE: 214-744-2400, FAX: 214-744-2401, [xray@rcamerica.com](mailto:xray@rcamerica.com)



/TeamXray



/TeamXray



/TeamXray



/TeamXrayRC



/XrayRacing



/XrayRacing